

**Aachen University of applied Sciences  
Campus Jülich**

Title of the Master Thesis

**Development of a hybrid system of solar collectors and a biomass furnace, with the use of the program C.A.R.N.O.T., for covering the needs in hot water of a hotel in Greece**

**by**

**Grigorios Gavriilidis**

**Matriculation number: 3057949**

Jülich, September 2015

This thesis is a partial fulfilment of the requirements for the degree of Master in Renewable Energy Sources (R.E.S.) of T.E.I. of WESTERN GREECE

This thesis was supervised by:

Prof. Dr.-Ing. Spiros Alexopoulos  
Solar-Institut Jülich

Prof. Dr.rer. nat. Gerd Breitbach  
Solar-Institut Jülich

Prof. Dr.-Ing. Burghard Müller  
Solar-Institut Jülich

This thesis was written independently.

There was no other literature used except the mentioned ones.

---

Jülich, September 2015

Copyright © Grigorios Gavriilidis, 2015  
All rights reserved.

Copying, storage and distribution of the present work, in whole or partly, for any commercial purpose, is forbidden. Reproduction, storage and distribution for non-profit, educational or research nature is allowed, provided to indicate the source of origin and to maintain the existing message. Questions concerning the use of the present work for profit use should address with the author.

The opinions and the conclusions contained in this document reflect the author and should not be interpreted as representing the official views of the Solar-Institut Jülich.

## Acknowledgements

This master thesis was elaborated within the Solar-Institut Jülich (SIJ), of the Aachen University of Applied Sciences, as part of the completion of my studies at the postgraduate program of studies of the Renewable Energy Sources (R.E.S.) of A.T.E.I. in Patra.

Preliminary, I would like to thank my supervisor Prof. Dr.-Ing. Spiros Alexopoulos for all the knowledge and the information that he provided to me during the seven months of my stay in Jülich. His guidance was decisive throughout all the steps of the development of my master thesis and that is why I am deeply indebted to him.

Secondly, I would like to thank the other two professors who supervised my master thesis, Prof. Dr.rer. nat. Gerd Breitbach and Prof. Dr.-Ing. Burghard Müller for their understanding and their time to spend reading my master thesis and preparing the appropriate questions during my examination.

Special thanks are definitely reserved to Prof. Dr. Socrates Kaplanis, who is the director of the MSc course on R.E.S. and president of A.T.E.I. in Patra, as long as all the other professors in the master course in Renewable Energy Sources. Thanks to their wisdom, their patience and their endless experience on the energy issues, they managed to teach me many interesting things that I'm sure that I will need in my later professional career.

Also I would like to thank the owner of the hotel "Demis apartments" in Sidari of Corfu, Mr. Babis Papaspiliou, for his continuous assistance and his immediate mobilization for the completion of the questionnaire which was created and related information regarding the hotel.

Of course I couldn't forget to say a big thanks to my fellow students with whom I had an excellent cooperation and thanks to the exchange of opinions between us, I believe that we all in fact benefited from it.

Last but not least, I would like to thank and simultaneously dedicate this master thesis to my parents George and Helen Gavriilidis, as well as my brother John Gavriilidis for all the help, love and support that they gave me through my life.

## Abstract

The purpose of the present master thesis is the development of a hybrid system which consists of solar collectors and a biomass furnace, with the use of the program C.A.R.N.O.T., for covering the needs in hot water of use in a hotel complex which consists of 9 studio apartments, in Sidari of Corfu, in Greece. The program C.A.R.N.O.T. (Conventional And Renewable eNergy systems OpTimization Blockset), was developed and promoted by the Solar-Institut Jülich in Germany.

In order to collect the necessary information (hotel occupancy, existing heating system of the water etc.) a questionnaire was created (which is included completed in the annex of the master thesis) and was sent to the owner of the hotel.

His response was immediate, because as he mentioned, he is interested very much about the specific master thesis, as in the future there is the possibility to proceed with the development of this hybrid system, mainly due to the rise of the oil price, which is used in the existing system, and for environmental reasons, because such a step would attract the tourists with environmental conscious.

From the questionnaire it was found that the hotel has already a boiler with an oil burner. For this reason, in the model which was created in the program, after the calculation of the surface of the flat plate collectors, in order to reduce the consumption of the oil, an assessment is being made of both the price of the oil, based on the current price, and the amount of the oil saved by the installation of the solar collectors. Then, instead of oil, and for the same surface of solar collectors, it is used a burner that burns wood pellets (biomass), of equal power with the oil burner. In this case it is calculated the value and quantity of the wood pellets required to heat the water use of the hotel, for the case that the owner of the hotel would like to change his oil burner with a biomass burner.

In the first chapter of the present master thesis a brief description of the forms of renewable energy is being done, with a more extensive reference to the solar energy, as well as its advantages and disadvantages. The types and the connections that exist between the solar collectors and the basic concepts required for the calculation and design of the solar collectors are mentioned. After this, the focus is set on biomass energy, in its advantages and disadvantages, in its physicochemical characteristics and the sources of its origin. Finally there is a brief description of the concept of the hybrid systems as well as their advantages and disadvantages.

In the second chapter there are listed all the software programs that were used for the development of the model, as well as their advantages and disadvantages. More specifically, these programs are: the MATLAB<sup>®</sup>, the Simulink<sup>®</sup>, the C.A.R.N.O.T. and the Meteonorm4.

The third chapter starts with the selection of the hotel, and all the data that concern both the hotel itself and the climate and the weather data of the surrounding area are reported. Specifically, subchapter 3.1 presents the selection of the hotel, with its latitude and longitude, and gives a short description of the rooms and the facilities which are available. In subchapter 3.2 the climate of the area during the whole year is mentioned. Continuously subchapter 3.3

describes in details the existing system of the hotel for heating the water of use during the period of operation, and also a detailed description of the data acquired (hotel occupancy per month, daily consumption of hot water, peak hours of consumption, etc.) from the completed questionnaire.

The beginning of the fourth chapter shows the meteorological data that had to be extracted in an hourly base from the program Meteonorm4 for the creation of the imported file of solar data to the flat plate collectors. Continuously there is a reference for the cycles of operation of the model. Subchapter 4.3 includes a description of the model, as it was created with the C.A.R.N.O.T. program. In subchapter 4.4 all the data that were used in all the blocks of the model are mentioned in detail.

In the fifth chapter there are mentioned the results and the diagrams of the simulation. More precisely, in subchapter 5.1 there are mentioned the results and the diagrams which concern the existing system that the hotel has for the heating of the water of use. Continuously in subchapter 5.2 there are mentioned the results and the diagrams for the system of the oil furnace with the flat plate collectors. In subchapter 5.3 there are given the results as long as the diagrams for the hybrid system of the biomass furnace and the flat plate collectors. Finally, in subchapter 5.4 a comparison of the diagrams which concern the three different cases is being made, which are examined in the present master thesis.

In the sixth chapter at last there are mentioned all the conclusions which were extracted by the creation of the specific model of simulation.

## Περίληψη

Ο σκοπός της παρούσας διπλωματικής εργασίας είναι η ανάπτυξη ενός υβριδικού συστήματος που αποτελείται από ηλιακούς συλλέκτες και έναν καυστήρα βιομάζας, με την χρήση του προγράμματος C.A.R.N.O.T. , για την κάλυψη των αναγκών σε ζεστό νερό χρήσης σε ένα ξενοδοχείο που αποτελείται από 9 διαμερίσματα στούντιο, στο Σιδάρι της Κέρκυρας, στην Ελλάδα. Το πρόγραμμα C.A.R.N.O.T. (Conventional And Renewable eNergy systems OrTimization Blockset) δημιουργήθηκε και αναπτύχθηκε από το Ηλιακό Ινστιτούτο του Jülich στην Γερμανία.

Για την συλλογή των αναγκαίων πληροφοριών (πληρότητα ξενοδοχείου, υπάρχον σύστημα θέρμανσης του νερού κ.α.) ένα ερωτηματολόγιο δημιουργήθηκε (το οποίο παρατίθεται συμπληρωμένο στο παράρτημα της διπλωματικής εργασίας) και στάλθηκε στον ιδιοκτήτη του ξενοδοχείου.

Η ανταπόκρισή του ήταν άμεση, καθώς όπως ανέφερε, ενδιαφέρεται πάρα πολύ για την συγκεκριμένη εργασία, καθώς στο μέλλον υπάρχει η πιθανότητα να προχωρήσει στην δημιουργία του συγκεκριμένου υβριδικού συστήματος, κυρίως λόγω της αύξησης της τιμής του πετρελαίου, που χρησιμοποιείται στο ήδη υπάρχον σύστημα, και για περιβαλλοντικούς λόγους, καθώς ένα τέτοιο βήμα θα προσέλκυε τους τουρίστες με περιβαλλοντική συνείδηση.

Από το ερωτηματολόγιο διαπιστώθηκε ότι το ξενοδοχείο διαθέτει ήδη λέβητα με καυστήρα πετρελαίου. Για αυτόν τον λόγο, στο μοντέλο που δημιουργήθηκε στο πρόγραμμα, μετά από τον υπολογισμό της συλλεκτικής επιφάνειας των ηλιακών συλλεκτών, έτσι ώστε να μειωθεί η κατανάλωση πετρελαίου, γίνεται και μια εκτίμηση τόσο της τιμής του πετρελαίου, με βάση την τρέχουσα τιμή του, όσο και της ποσότητας του που εξοικονομείται από την εγκατάσταση των ηλιακών συλλεκτών. Στην συνέχεια, αντί για πετρέλαιο, και για την ίδια επιφάνεια ηλιακών συλλεκτών, χρησιμοποιείται καυστήρας που καίει πέλλετ ξύλου (βιομάζα), ίδιας ισχύος με τον καυστήρα πετρελαίου. Σε αυτή την περίπτωση υπολογίζεται η τιμή και η ποσότητα των πέλλετ ξύλων που απαιτούνται για να θερμάνουν το νερό χρήσης του ξενοδοχείου, για την περίπτωση που ο ιδιοκτήτης του ξενοδοχείου θα ήθελε να αλλάξει τον καυστήρα πετρελαίου με καυστήρα βιομάζας.

Στο πρώτο κεφάλαιο της παρούσας διπλωματικής γίνεται μια σύντομη περιγραφή των μορφών των ανανεώσιμων πηγών ενέργειας, με μια ποιο εκτεταμένη αναφορά στην ηλιακή ενέργεια, καθώς και στα πλεονεκτήματα και τα μειονεκτήματά της. Οι τύποι και οι συνδέσεις που υπάρχουν ανάμεσα στους ηλιακούς συλλέκτες και οι βασικές έννοιες που απαιτούνται για τον υπολογισμό και την σχεδίαση των ηλιακών συλλεκτών αναφέρονται. Μετά το ενδιαφέρον επικεντρώνεται στην ενέργεια της βιομάζας, στα πλεονεκτήματα και μειονεκτήματά της, στα φυσικοχημικά χαρακτηριστικά της και στις πηγές προέλευσής της. Τέλος γίνεται μια περιορισμένη περιγραφή της έννοιας των υβριδικών συστημάτων καθώς και των πλεονεκτημάτων και των μειονεκτημάτων τους.

Στο δεύτερο κεφάλαιο αναφέρονται όλα τα λογισμικά προγράμματα που χρησιμοποιήθηκαν για την ανάπτυξη του μοντέλου, καθώς επίσης και τα πλεονεκτήματα και

τα μειονεκτήματα τους. Ποιο συγκεκριμένα, τα προγράμματα αυτά είναι: η MATLAB®, το Simulink®, το C.A.R.N.O.T. και το Meteonorm4.

Το τρίτο κεφάλαιο ξεκινάει με την επιλογή του ξενοδοχείου και αναφέρονται όλα τα στοιχεία που αφορούν τόσο το ίδιο το ξενοδοχείο, όσο και το κλίμα και τα μετεωρολογικά δεδομένα της γύρω περιοχής. Αναλυτικότερα, το υποκεφάλαιο 3.1 παρουσιάζει την επιλογή του ξενοδοχείου, με το γεωγραφικό πλάτος και μήκος του, και γίνεται μια σύντομη περιγραφή των δωματίων και των εγκαταστάσεων που διαθέτει. Στο υποκεφάλαιο 3.2 αναφέρεται το κλίμα της περιοχής κατά την διάρκεια ολόκληρου του έτους. Στην συνέχεια στο υποκεφάλαιο 3.3 περιγράφεται αναλυτικά το ήδη υπάρχον σύστημα που χρησιμοποιεί το ξενοδοχείο για την θέρμανση του νερού χρήσης, κατά την περίοδο λειτουργίας του, καθώς και μια αναλυτική περιγραφή των δεδομένων που αποκτήθηκαν (πληρότητα ανά μήνα, ημερήσια κατανάλωση ζεστού νερού, ώρες αιχμής κατανάλωσης κ.α) από το συμπληρωμένο ερωτηματολόγιο.

Η αρχή του τέταρτου κεφαλαίου δείχνει τα μετεωρολογικά δεδομένα που χρειάστηκε να εξαχθούν σε ωριαία βάση από το πρόγραμμα Meteonorm4 για την δημιουργία του αρχείου εισαγωγής ηλιακών δεδομένων στους ηλιακούς συλλέκτες. Στην συνέχεια γίνεται μια αναφορά στους κύκλους λειτουργίας του μοντέλου. Το υποκεφάλαιο 4.3 περιλαμβάνει την περιγραφή του μοντέλου, όπως αυτό δημιουργήθηκε με το πρόγραμμα C.A.R.N.O.T. Στο υποκεφάλαιο 4.4 αναφέρονται αναλυτικά όλα τα δεδομένα που χρησιμοποιήθηκαν σε όλα τα μπλοκ του μοντέλου.

Στο πέμπτο κεφάλαιο αναφέρονται τα αποτελέσματα καθώς και τα διαγράμματα της προσομοίωσης. Ποιο συγκεκριμένα, στο υποκεφάλαιο 5.1 αναφέρονται τα αποτελέσματα και τα διαγράμματα που αφορούν το υπάρχον σύστημα που διαθέτει το ξενοδοχείο για την θέρμανση του νερού χρήσης. Στην συνέχεια στο υποκεφάλαιο 5.2 αναφέρονται τα αποτελέσματα και τα διαγράμματα για το σύστημα του καυστήρα πετρελαίου, μαζί με την προσθήκη των ηλιακών συλλεκτών. Στο υποκεφάλαιο 5.3 δίδονται τα αποτελέσματα μαζί με τα διαγράμματα για το υβριδικό σύστημα του καυστήρα βιομάζας μαζί με τους ηλιακούς συλλέκτες. Τέλος στο υποκεφάλαιο 5.4 γίνεται μια σύγκριση των διαγραμμάτων που αφορούν και τις τρεις διαφορετικές περιπτώσεις οι οποίες εξετάζονται στην παρούσα διπλωματική εργασία.

Στο έκτο κεφάλαιο τέλος αναφέρονται τα συμπεράσματα τα οποία εξήχθησαν από την δημιουργία του συγκεκριμένου μοντέλου προσομοίωσης.

# Contents

<b>Chapter 1-Theory</b> .....	9
1.1 Forms of renewable energy sources .....	9
1.2 Solar Energy .....	10
1.2.1 Advantages and disadvantages of the solar energy .....	10
1.2.2 Solar potential in Greece .....	11
1.2.3 Solar thermal collector.....	12
1.2.4 Types of solar collectors.....	13
1.2.5 Basic concepts for the calculation and the design of the solar collectors.....	16
1.3 Biomass energy .....	18
1.3.1 Advantages and disadvantages of biomass energy.....	19
1.3.2 Biomass characteristics.....	19
1.3.3 Sources of biomass .....	20
1.4.1 Advantages and disadvantages of the hybrid systems.....	23
<b>Chapter 2-Software programs used for the development of the model</b> .....	24
2.1 MATLAB® software .....	24
2.2 Simulink® software .....	26
2.3 C.A.R.N.O.T. software.....	28
2.4 Meteonorm4 software.....	30
<b>Chapter 3-Hotel selection and meteorological data of the area</b> .....	32
3.1 Selection of the hotel.....	32
3.2 Climate of Corfu.....	34
3.3 Data and existing system in the hotel.....	35
<b>Chapter 4-Development of the model with the C.A.R.N.O.T. software</b> .....	39
4.1 Weather data.....	39
4.2 Description of the cycles of the model.....	42
4.3 Creation of the model in C.A.R.N.O.T. program.....	44
4.4 Block parameters of the model.....	46
<b>Chapter 5-Simulation results</b> .....	54
5.1 Simulation results for the existing system of the oil burner (without collectors) .....	54
5.2 Simulation results of the oil burner with the flat plate collectors .....	62
5.3 Simulation results for the biomass burner by adding the flat plate collectors .....	68



5.4 Comparison between the different cases under examination .....	75
<b>Chapter 6-Conclusions</b> .....	<b>83</b>
References .....	85
Annex .....	88
A.1 Completed questionnaire from the owner of the hotel .....	88
A.2 Description of the blocks used in the C.A.R.N.O.T. software program.....	90

# Chapter 1-Theory

## 1.1 Forms of renewable energy sources

The origin of the Renewable Energy Sources (R.E.S.) is based mainly on the energy of the sun. The sun's solar radiation that impinges on the earth provides huge amounts of energy, which can be exploited in various forms.

The R.E.S. have distinguishing characteristics. First of all, for their exploitation no energetic intervention is needed, such as mining or pumping, and it is based on the existing energy flow inside nature. Second, it is a very "clean" form of energy, as it is friendly to the environment and it does not release hydrocarbons, carbon dioxide or toxic and radioactive wastes to the environment, as other energy sources which are used on a large scale. For these reasons the R.E.S can be a solution to the environmental problems of the earth, and therefore they are studied as a solution to the expected depletion and replacement of the conventional (non-renewable) fossil fuel reserves.

The R.E.S. can replace the conventional fuels in four distinct areas: **electricity generation, air and water heating/cooling, motor fuels, and rural (off-grid) energy services** [1].

For that, several countries all around the world have adopted new policies based on the economical development and use of the R.E.S.

The most important forms of the R.E.S. (Fig.1.1) [2] are:

- Solar energy
- Wind energy
- Hydraulic energy
- Geothermal energy
- Biomass energy
- Ocean energy



Fig.1.1: The forms of Renewable Energy Sources [3]

In the following subchapters, only the solar energy and the biomass energy will be considered, since only these two are the subject of study for the specific master thesis.

## 1.2 Solar Energy

The Solar Energy constitutes the most important and the most useful form of all the forms of renewable energy sources because, as it is shown in the figure beside (Fig.1.2), the amount of the energy potential that the solar energy can provide may override the needs of energy of the global consumption.

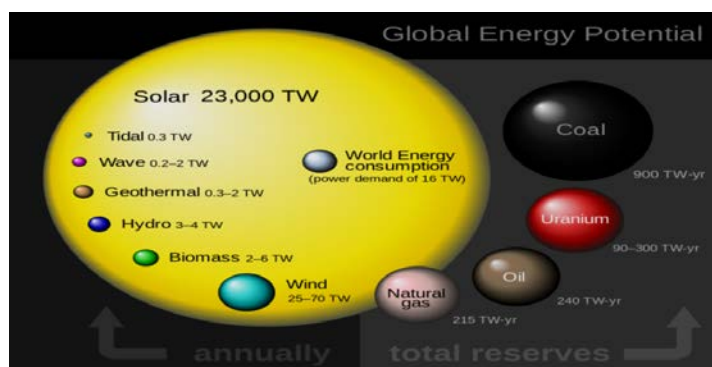

Fig.1.2: Global energy potential of Renewable and non Renewable energy sources [4]

The spectrum of the sunlight, as a portion of the electromagnetic radiation which is given by the sun, is divided into **infrared**, **visible**, and **ultraviolet** light. The ultraviolet light spans a range of 200 nm up to 400 nm in the axis of wavelength, it represents the 9 % of the total solar radiation and it is invisible to human eye. The visible light spans a range of 380 nm up to 780 nm, it is the strongest output range of the sun's total irradiance spectrum as it represents the 49 % and it is visible to human eye. The infrared light span 700 nm up to 1 mm, it represents the 42 % of the total solar radiation and it is responsible for an important part of the electromagnetic radiation that reaches the earth. The solar radiation that is suitable for thermal applications ranges from 380 nm up to 3000 nm [5].

The technologies that are broadly used either to capture and distribute the solar energy or to convert it into solar power, characterize the solar energy as either **passive** or **active**. The active solar energy techniques include the use of photovoltaic systems, concentrated solar power and solar water heating. The passive solar energy techniques include orienting a building to the sun, selecting materials with favorable thermal mass or light dispersing properties, and designing spaces that naturally circulate air.

### 1.2.1 Advantages and disadvantages of the solar energy

The main advantages of the solar energy [6] and its use are listed below:

- ✓ "clean" form of energy and environmental friendly
- ✓ infinite, and therefore reliable, as opposed to the oil reserves that are estimated to last for 30 - 40 years
- ✓ can be used in remote areas where it is too expensive to extend the electricity power grid
- ✓ used effectively to power up a large amount of devices such as calculators and other devices
- ✓ provides income to the owner
- ✓ creates jobs (see Fig.1.3)

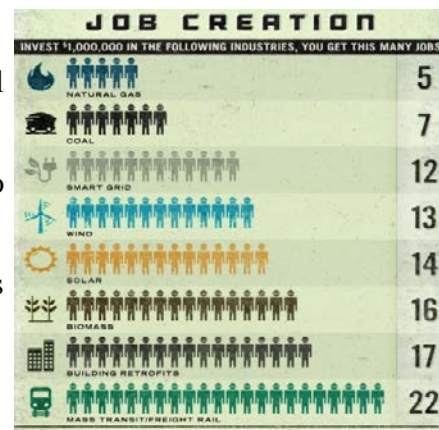

Fig.1.3: One of the advantages of solar energy [7]

- ✓ reduces the greenhouse effect

But the solar energy does not have only advantages. The few disadvantages [6] of the solar energy are the next ones:

- ✓ solar energy can only be harnessed when it is daytime and it is reduced significantly when it is cloudy, or turns to zero during the night
- ✓ the technology used to harness the solar energy is still expensive.
- ✓ it demands a lot of space in order to be harnessed.

## 1.2.2 Solar potential in Greece

The energy production in Greece is covered by D.E.H. (public power cooperation), which was founded in 1950 in a monopolistic basis for the production and distribution of electric energy. In 2006, the development of the solar energy production started in Greece with the installations of photovoltaic systems, and by 2009 these installations were skyrocketed due to the appealing feed-in tariffs and the corresponding regulations for domestic applications. Due to that boom, new regulations were imposed in August 2012 to all operating photovoltaic power stations, having as a result the drastic reduction of the feed-in tariffs [8]. So, all the new licenses for the exploitation of the solar energy were stopped.

Another important sector is the production of heat from solar energy. Greece has been a pioneer in the European Union from the decade of 70's in the development of solar thermal collectors for the supply of heat with a remarkable industry. According to the Union of Industries of Solar Energy, in Greece nowadays the 40 % of the industrial production in solar collectors is exported in countries outside and inside the European Union, while the sector of production employs around 3500 employees [9]. The solar thermal collectors in Greece are substituting mainly the electrical energy (around 3 % today), thus reducing the emissions of CO<sub>2</sub> with economical and environmental benefits, contributing at the same time to the energy security and the fulfillment of the national targets. It is estimated that without the operation of the solar thermal systems in Greece it would be needed the construction and operation of a power plant of at least 600 MW in order to supply the same amount of heat.

The total installed surface of solar thermal collectors for heating water in European Union is calculated to be  $43 \cdot 10^6 \text{ m}^2$  (with a potential that reaches  $1.4 \cdot 10^9 \text{ m}^2$ ), which is equal to 30.2 GW<sub>th</sub>. In Greece, the total installed surface of the solar thermal collectors is estimated to  $4.1 \cdot 10^6 \text{ m}^2$  or 2.9 GW<sub>th</sub> [10]. Part of this success of the installed surface of the solar thermal collectors is attributed to the tax incentives that the Greek government adopted. All around the world, Greece possess the fifth place of the higher total installed thermal power per person (265.8 KW<sub>th</sub> per 1000 persons).

From these data it is obvious that Greece has an enormous energy potential, as can be observed in the following map (Fig.1.4).

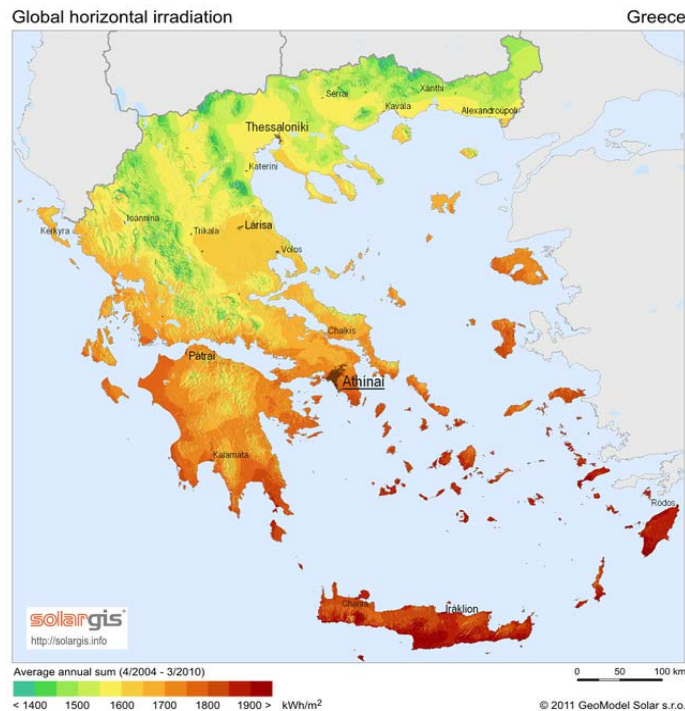

Fig.1.4: Global horizontal irradiation map of Greece [11]

From measurements that were made, it was found that Greece has about 250 days / year of sunny weather, meaning more than 3000 hours / year.

Unfortunately the main problem in Greece is the bureaucracy that puts as many obstacles in the way as possible. The Greek government has been working on the modernization of the country's legal framework for years, in an attempt to promote renewable energies. For that, in 2011 project Helios [12] was announced, an ambitious program of installation of the biggest solar power plant in the world, with installed capacity of 10 GW by 2050. Although 4 years have passed since the announcement, the location for the installation of this project which could alleviate the financial situation of Greece, in the middle of the economical crisis, has not yet been determined.

### 1.2.3 Solar thermal collector

The exploitation of the solar energy for the production of heat is done with different types of solar collectors.

The **solar collector** is a special form of heat exchanger that absorbs the solar radiation and transfers the energy to the fluid, which crosses the collector through a system of pipes, and is the heart of an every solar heating system. The fluids that are used in solar collectors are: water, water with glycerol, oil or even air. There are several types of solar collectors, which will be analyzed in subchapter 1.2.4:

- Flat plate solar collectors
- Unglazed solar collectors
- Evacuated tube collectors

- Small concentrating solar collectors

The function of the solar thermal collector is based on the natural phenomenon of the fluid flow due to the difference of density. The fluid flow is achieved without the use of any pump, from the hottest spot (solar collector) to the coldest spot (water tank), until the two spots obtain almost the same temperature. In order for that to happen, the coldest spot must be higher than the hottest spot, and that is why in all the solar collectors the water tank is always higher than the solar collector. The overall efficiency of the solar collector depends also from the ambient temperature, the cloud cover factor and the effectiveness of the insulation of the whole system.

### 1.2.4 Types of solar collectors

There are several types of solar collectors, according to their characteristics. First of all, according to the circulation of the water they are separated to:

- **Open loop solar collectors:** In these solar collectors there is a direct heating of the water of use.
- **Closed loop solar collectors:** In these solar collectors there is an indirect heating of the water of use.

The open loop solar collectors are cheaper than the closed loop solar collectors but they are having some problems in low temperatures, as the water does not contain anti-freezing mix. On the contrary, in the closed loop solar collectors, due to the fact that the heating fluid is circulating in a separate system, it can be another fluid but water.

Also, according to their storage tank and depending on the number of energy sources that can exploit, they are divided to:

- **Double energy solar heaters:** Are the solar water heaters that may exploit the solar energy and the electric energy, according to the user's demand. For that reason they also have an electrical resistance inside.
- **Triple energy solar heaters:** Are the solar water heaters that they are working like the double energy solar water heaters, but they can also exploit the energy from the heating system of the house, in order to heat the water.

Finally, as it is mentioned in subchapter 1.2.3, the solar collectors can be divided to:

- **Flat plate solar collectors:** They are the most common type of solar collectors for house solar systems of heating water. As it is shown in the following figure (Fig.1.5), they are consisted of the following parts:
  - Glazing: The solar collector's glazing is mainly used to avoid the heat losses of the system, and that is the reason why the thickness of the glaze plays an important role to the performance of the solar collector. It is exposed to high temperatures, long time outside exposure and impacts of vandalism, so it has to have certain properties like:
    - ✓ high temperature capability

- ✓ very well transmission of the light
  - ✓ good impact resistant
  - ✓ low cost
  - ✓ light weight and easy to work
  - ✓ long life
  - ✓ opaque to long IR to reduce heat loss
- Flow tubes and header: Pipes into which the water of use is heating.
  - Dark absorber plate: Transfers the absorbed solar energy, which is converted to heat, in the fluid which is circulating inside the flow tubes and the header.
  - Insulation: It is used in order to reduce the thermal losses in the back side of the solar collector.
  - Inlet pipe: Tube inside which the cold water coming from the water tap circulates.
  - Outlet pipe: Tube in which the hot water that goes to the storage tank circulates.

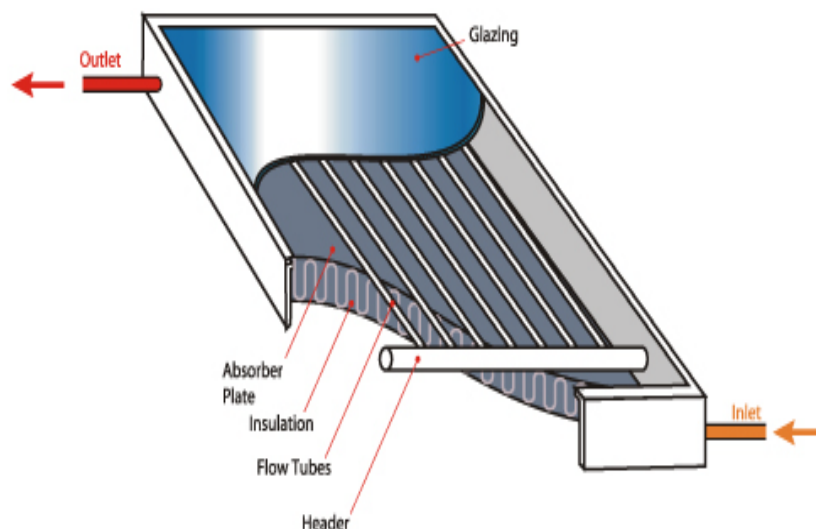

Fig.1.5: Flat plate collector's parts [13]

- **Unglazed solar collectors:** They were used in the past for preheating ventilation of air for a building. They are similar to the flat plate solar collectors, only that they don't have any glazing over top. They include the dark absorber plate, only this absorber has holes or perforations in order for the air to move among them. The unglazed solar collectors are usually wall-mounted to capture the lower sun angle in the winter heating months as well as sun reflection off the snow and achieve their optimum performance. Except from wall-mounted, they can also be roof-mounted if there are no available walls facing south, or for other applications. They have certain advantages as:
  - ✓ reduced cost through the use of less expensive absorber materials
  - ✓ less expensive than the flat plate collectors
  - ✓ fast payback period

✓ quick and easy installation

- Evacuated tube collectors:** The evacuated tube collectors consists of a number of rows of parallel transparent cylindrical glass tubes connected to a header pipe, as it is shown in the following figure (Fig.1.6). Each tube consists of a thick glass outer tube and a thinner glass inner tube that absorbs solar energy but inhibits heat loss. The air between the outer and the inner tube is removed, forming a vacuum. Inside each glass tube, a flat or curved aluminum or copper absorber plate is attached to a metal heat pipe running through the inner tube. The solar radiation heats the absorbed plate, and via convection the metal pipe is heated too. Inside the metal pipe freon fluid is flowing, which ends in the heat exchanger. The heat exchanger heats the pipe of the cold water, and all the hot water that comes out is stored in a tank with insulating properties. In this way, the hot water can be used at night, or even the next day. A basic problem of the evacuated tube collector is that if for any reason this vacuum is damaged or destroyed, then the whole system is not working. Its main advantage is the achievement of high temperatures of hot water (up to 150 °C) which can be used for industrial use.

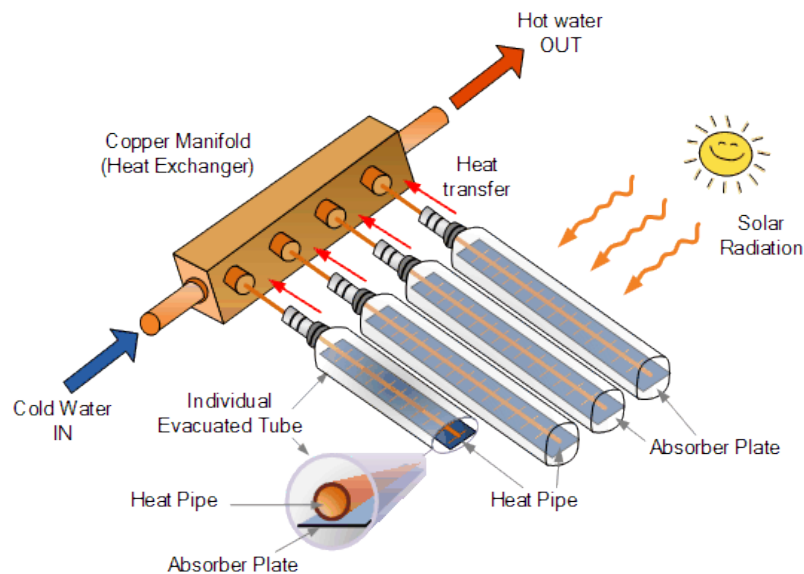

Fig.1.6: Parts composing an evacuated tube collector [14]

- Concentrating solar collectors:** They use reflective surfaces in order to concentrate the sun light into a smaller area, where it is absorbed and converted to heat. The concentrations can increase the sun's power flux by hundreds of times. They are separated to different principal types like:
  - compound parabolic
  - parabolic trough
  - fixed reflector and moving receiver
  - fixed receiver and moving reflector
  - fresnel lens
  - central receiver



Their advantages, compared to the flat plate solar collectors are that they can achieve very high temperatures of the heating fluid, which is useful in industrial applications and power production and the small heat losses of the absorbing surface due to its small size. Further advantages are the possibility to store heat and the hybridization. With these two characteristics high operation hours of such plants can be achieved. But on the other hand, the extreme highly cost of their production, and also the fact that they only exploit the direct solar radiation (as opposed to the flat plate solar collectors that they exploit the direct and the diffuse solar radiation), are their main disadvantages.

### 1.2.5 Basic concepts for the calculation and the design of the solar collectors

The sun radiates energy, based on the equation  $E = m \cdot c^2$ , where  $E$  is the energy that the sun produces,  $m$  is the mass of the sun and  $c$  is the speed of light in vacuum (and it's equal to  $2.99792458 \cdot 10^8$  m / s). Part of this energy is heading for the earth, under the form of electromagnetic radiation, and a percentage of this energy (about 2 / 3) is absorbed by the earth, while another percentage (about 1 / 3) is reflected to space. The radiation that reaches the earth varies during the year, due to the elliptic orbit of the earth around the sun, and ranges from  $1353$  W / m<sup>2</sup> up to  $1395$  W / m<sup>2</sup>.

**Direct solar radiation  $H_b$**  [15] is defined as the radiation that reaches the surface of the earth, from the sun, without being scattered in the atmosphere. It is also called "beam radiation" or "direct beam radiation". It is measured in J / m<sup>2</sup> and for computational reasons it is analyzed in horizontal and vertical component as to the surface of the earth. The horizontal component does not contribute to the production of solar energy.

The **diffuse solar radiation  $H_a$**  is the radiation that comes from the diffuse of the direct solar radiation in the atmosphere or from different objects or from the ground, and it is measured in J / m<sup>2</sup>. It contributes to the production of solar energy, so it is imperative to know the amount of the diffuse solar radiation that finally reaches the surface under examination.

The **total solar radiation  $H$**  is the sum of the direct and the diffuse solar radiation on a surface and it is measured in J / m<sup>2</sup>.

The **radiation power density** (irradiance, measured in W / m<sup>2</sup>) is the rate at which the energy which radiates falls on a surface, per surface unit.

The **density of irradiation energy** (irradiation, measured in W / m<sup>2</sup>) is the impinging energy to a surface area per unit area, and it is calculated by the integral of the power density for a specific time period (for this master thesis its 1 hour).

As **inclination of the solar collector  $\beta$**  is defined the angle between the flat plate collector and the horizontal plane, and it ranges from  $0^\circ$  up to  $90^\circ$ .

The **azimuth angle  $\gamma$**  [16] is the planar rotation of the surface to east or west. The azimuth angle is zero when the perpendicular projected line coincides with the north-south direction. For the solar collectors applies that  $-90^\circ < \gamma < 90^\circ$ .



### 1.3 Biomass energy

Biomass is the oldest and most widely used R.E.S. Primitive man, in order to warm up and cook, used its energy (heat) that came from the burning of woods, which is a kind of biomass.

**Biomass** is called all the earth's living matter that is using the solar energy in chemical form. It can be formed by all organic materials from plants, trees, crops, animal's mature and algae. The components of biomass include cellulose, hemicelluloses, lignin, extractives, lipids, proteins, simple sugars, starches, water, HC, ash, and other compounds.

The energy, which is stored in plants and animals, or in the wastes that they produce, is called **biomass energy**. As an energy source, biomass can either be used directly via combustion to produce heat, or indirectly after converting it to various forms of biofuel. Conversion of biomass to biofuel can be achieved by different methods which are broadly classified into: **thermal, chemical, and biochemical** methods. These may be categorized as follows: direct combustion, pyrolysis, gasification, liquefaction, supercritical fluid extraction, anaerobic digestion, fermentation, acid hydrolysis, enzyme hydrolysis, and esterification. Nowadays, direct combustion and co-firing with coal, is the most important technology, as it is calculated that more than 97 % of the bio-energy production derives from it.

The world production of biomass is estimated at 146 billion metric tons per year. Biomass is an important factor of each country's financial strength, and researches [18] [19] have shown that in the future each country will be able to preserve its own energy reliance thanks to biomass.

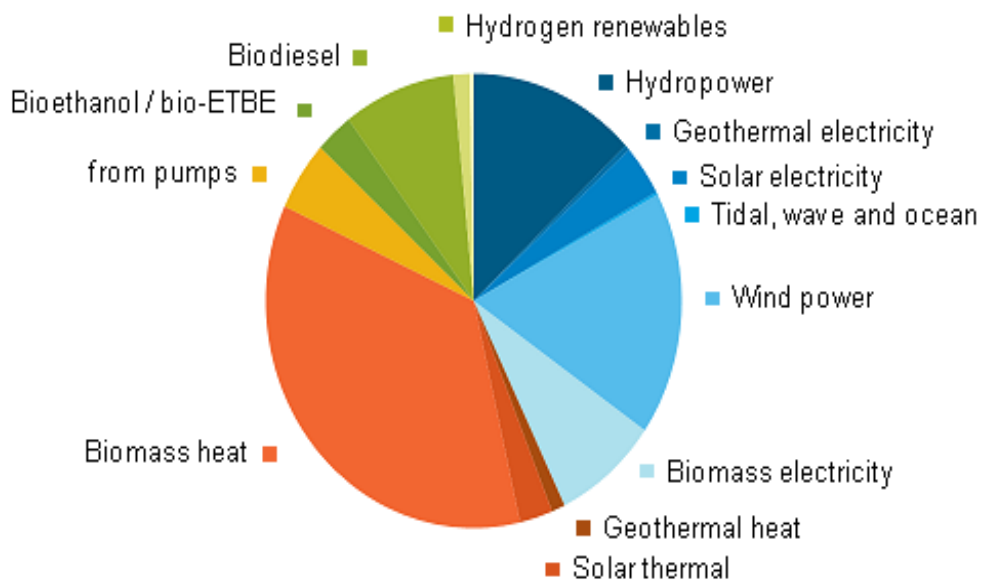

Fig.1.8: Pie chart of R.E.S. in Europe

As it is shown in the figure above (Fig.1.8), biomass accounts in Europe 68.5 % of the R.E.S., mainly in the form of solid wood used for heating.

The biomass can be used in three different ways: **burned**, in order to produce heat and electricity, **change to gas fuels** such as methane, hydrogen and carbon monoxide or **change to a liquid fuel** (ethanol and methanol).

The different types of biomass burners can be combined with one or more of the other forms of R.E.S. for the construction of a hybrid system. The most common combination of the biomass burners is with solar collectors or with photovoltaic panels.

### 1.3.1 Advantages and disadvantages of biomass energy

There are several important advantages [20] [21] which characterize the biomass as a R.E.S. These are the following:

- ✓ renewable source of energy
- ✓ comparatively less pollution generating energy
- ✓ helps in cleanliness in villages and cities
- ✓ provides manure for the agriculture and gardens
- ✓ tremendous potential to generate biogas energy
- ✓ relatively cheaper and reliable
- ✓ can be generated from everyday human and animal wastes, vegetable and agriculture left-over etc
- ✓ recycling of waste reduces pollution and the spread of diseases
- ✓ growing biomass crops use up carbon dioxide and produces oxygen
- ✓ heat energy from biogas is 3.5 times more than the heat from burning wood.

On the other hand, the disadvantages associated with the use of biomass are the following:

- ✓ modern and improved biomass conversion technologies require expensive equipment, compared to that of conventional fuels
- ✓ continuous supply
- ✓ requires space and produces dirty smell
- ✓ inefficient working due to improper construction
- ✓ difficult to store biogas in cylinders
- ✓ difficult transportation of biogas through pipes over long distances
- ✓ crops which are used are seasonal and are not available over the whole year.

### 1.3.2 Biomass characteristics

There are four significant physicochemical characteristics of the solid biomass that determine both the final rate of the biomass utilization, and generally if the entire investment is viable or not. Depending on the source of biomass, these characteristics can vary enormously in their values. They need to be analyzed in order to avoid possible problems related to the use of biomass and for increasing its effectiveness. These characteristics [22] are:

- **Calorific value:** It is one of the most important characteristic of the fuel, because it indicates the total amount of energy that is available in the fuel. It can be expressed by two ways: the **higher heating value** (HHV) and the **lower heating value** (LHV). The HHV represents the total heat energy that is available in the fuel, while the LHV is the total heat energy minus the energy of the water vaporization of the fuel. The HHV is sometimes called Gross Calorific Value (GCV), while the LHV is also called and Net Calorific Value (NCV).
- **Moisture content:** It is obvious that the lower the moisture level of a fuel, the higher the useful heat per unit mass. On the other hand, if a fuel is extremely dry, then it causes other problems, such as extreme dust. For the measurement of the moisture content there are two methods: the **wet basis** method and the **dry basis** method. In the first method the percentage of the moisture equals to the mass of the water divided by the total mass of the fuel, while in the second method, the percentage of the moisture equals to the mass of the water divided by the mass of the dry portion of the fuel.
- **Fuel size and density:** These are the most over-looked characteristics of the fuel performance, but they should be examined at the final selection of the fuel. They affect the rate of the heating and drying during the combustion process. The fuel size defines the type of the handling equipment that is going to be used, and a false evaluation in this characteristic could have an impact on the efficiency by damaging the handling equipment. As the biomass is almost shredded, the most appropriate word for the density would be the bulk density, as it is the fraction of the density per piece.
- **Composition:** The three most important compositional parameters of the biomass fuel are:
  - a) the ash content,
  - b) the susceptibility to slagging and fouling
  - c) the percent of the volatiles.

The ash content can reduce the combustion efficiency and choke up the equipment. Slagging and fouling occur when the ash starts to melt, and they can be minimized by keeping the combustion temperature low, so that the ash won't melt. The percent of the volatiles is the fraction of the fuel that will turn to gas when it is heated to a high temperature. This affects the combustion chamber, as fuels with high percent of volatiles tend to vaporize before the combustion.

### 1.3.3 Sources of biomass

The sources of biomass can be classified in five categories. These are:

- wood remains
- agriculture waste
- energy crops
- animal waste

- municipal waste

The **wood remains** [23] are the largest biomass energy source today, and the oldest type of energy used by humans in order to protect from the cold weather and to cook. Even today the wood remains are used mostly for the coverage of thermal loads and rarely for the production of electricity. They derive from the felling of the forests, the trees pruning, the processing of the timber and the paper industry (the liquid fuel known as "black liquor"). The point of collection, the total available amount, the cost of the equipment of collection, the demands in preprocessing or drying, the distance of transportation and the cost of final production are the main parameters that define the final cost of the wood remains as a biomass source.

The **agriculture wastes** [24] refer to the organic products from agriculture that are not sold as food nor used in the manufacturing of other goods. Mostly, this biomass is in the form of residual stalks from crops, leaves, roots, seeds and seed shells. Agricultural wastes are characterized by seasonal availability and have characteristics that differ from other solid fuels such as wood, charcoal and char briquette. The main differences are the high content of volatile matter and the lower density and burning time. This form of biomass production is not widespread, and the reason is because the governments and local authorities in developing countries are largely unaware of the immense potential of the agriculture waste. The countries also lack the capability to assess different technology options in order to select those which will be the most suitable for local application.

The **energy crops** [25] are cultivated or wild species, traditional or new, have particularly high capacity storage and produce biomass as a main product, which can be used for various purposes such as heat and electricity and the production of liquid biofuels.

Especially for Greece, the energy crops that can be cultivated for the production of liquid fuels are the following: sunflower, rapeseed, soybeans and other oilseed plants for biodiesel, and for bioethanol: sweet sorghum, wheat, corn, beets, barley and others. For the production of solid biofuels suitable are: eucalyptus, false acacia, cane, miscanthus, cardoon, cellulosic sorghum, kenaf, switchgrass and others. Finally, for the production of gas biofuels the following can be used: cardoon, sorghum, corn and others.

There is a wide range of **animal wastes** [26] that can be used as sources of biomass energy. The most common sources are animal and poultry manure. In the past this waste was recovered and sold as a fertilizer or simply spread onto the agricultural land, but in recent years, tighter environmental laws were voted that concern the smell and the protection of the groundwater contamination which provides further incentives for the animal waste-to-energy conversion. The basic method of exploiting the animal wastes is through anaerobic digestion (a natural process of decomposing the organic substances with the help of a broad spectrum of microorganisms in the absence of oxygen) which produces biogas.

The **municipal wastes** [27] comprise millions tones of household wastes which are collected every day and in the vast majority are disposed in sanitary landfills. The composition of these wastes varies greatly from country to country, according to their development, but even today a high percentage of the household wastes contain material that

could be converted to energy by direct combustion or by natural anaerobic digestion. The municipal wastes can be classified to the following categories:

- **biodegradable waste** such as food and kitchen waste, green waste, paper etc
- **medical waste** as needles, blades, scalpels etc
- **toxic waste** like pesticides, herbicides, fungicides and others
- **hazardous wastes** such as paints, spray cans, chemicals, fertilizer and containers
- **electrical and electronic waste** as refrigerators, TVs, computers and others
- **inert waste** like construction and demolition waste, rocks etc
- **composite waste** such clothes, tetra packs, toys
- **recyclable waste** such as paper, metals, certain plastics, bottles, cans and others.

## 1.4 Hybrid systems

Due to the fluctuations in the energy production of each of the forms of the R.E.S. separately (e.g. the solar energy depends on the clouds, or the fact whether it is day or night, the wind energy depends on the wind speed etc.) it was deemed necessary to search for solutions to ensure the reliability and quality of energy. In that direction, the hybrid systems constitute a sector that can deliver greater energy efficiency.

A **hybrid energy system** is any autonomous system of electricity production, in which it is incorporated more than one energy source that is working together with the necessary supporting equipment, including storage of the energy, in order to provide electricity to the network or for system demand.

The main parts constituting the hybrid energy system are:

- the energy production units,
- the energy storage unit,
- the control unit of the electricity produced and the coordination of the various options available to best meet their needs.

Necessary condition in order to qualify a system as hybrid is at least one of the production methods to use as source the R.E.S.

### 1.4.1 Advantages and disadvantages of the hybrid systems

The main advantages of the use of the hybrid systems are listed beneath:

- ✓ reliability of the system, as R.E.S. depend on weather conditions, which show large fluctuations such as the wind speed and the solar radiation
- ✓ exploit the best features of each technology that is used and thereby they ensure high efficiency
- ✓ meet the load even in case of low renewable dynamic
- ✓ contribute to the diversification of the energy sources, thus avoiding the dependence on certain energy sources
- ✓ achieve cost-efficiency of the conventional units as they are loaded with stable power and near the lowest specific fuel consumption.

The main disadvantages of the hybrid energy systems are:

- ✓ high cost of construction
- ✓ high cost of controlling the whole installation.
- ✓ huge space requirement in order to store all this energy.



## Chapter 2-Software programs used for the development of the model

### 2.1 MATLAB® software

MATLAB® [28] is a high-performance language and interactive environment for technical computing which integrates computation, programming and visualization. MATLAB® users can analyze data, acquire data, solve difficult mathematical equations and do some computing, develop algorithms, create models and applications, create scientific and engineering graphs and make data analysis. The language, tools and math functions that the MATLAB® program provides enables the users to explore multiple solutions and come to a solution to the problem faster than the spreadsheets or the programming languages. The name MATLAB® is an abbreviation for MATrix LABoratory.

The MATLAB® system consists of five main parts which are the following:

- **The language:** It is a high-level matrix language which has control structures, functions, data structures, inputs and outputs and object oriented programming features. The MATLAB® API allows to author C and Fortran programs to interact with it.
- **Desktop tools and development environment:** It is a set of tools and facilities that helps the user to become more creative with the MATLAB® functions and files.
- **Mathematical function library:** It comprises a vast collection of computational algorithms ranging from simple mathematical functions as sum, minus, cosine, sine up to more complex arithmetic functions such as matrix inverse, Bessel functions and fast Fourier transforms.
- **Graphics:** It is a subsystem that has extensive facilities for displaying vectors and matrices as graphs, as well as printing these graphs. The high level functions allow two dimensional and three dimensional data visualization, image processing and presentation of the graphics, while low level functions allow customizing the graphics appearances and also building of complete graphical user interfaces. But MATLAB® can also run without any graphics, just by typing a line of commands, if this is necessary (when the connection is too slow or when scripts need to run without displaying the plots).
- **External Interface:** It allows the user to write in C and FORTRAN programs and interact with MATLAB®. The external interface also contains facilities for calling routines from MATLAB® and for writing and reading MAT-files.

The advantages of the MATLAB® software over the conventional computer languages for technical problem solving are:

- **The easiness:** Programs can be easily written and modified with the integrated development environment and debugged with the MATLAB® debugger. For that reason it is ideal for rapid prototyping of new programs.

- **Multiple platforms:** It provides a large measure of platform independence due to the fact that it is supported on many different computer systems like Windows NT / 2000 / XP, Linux, several versions of UNIX and Macintosh.
- **Device-Independence:** Unlike most other computer languages, MATLAB® has many integral plotting and imaging commands. The plots and images can be displayed on any graphical output device supported by the computer on which MATLAB® is running.
- **Built-in function library:** It has an extensive library of predefined functions that provide tested and pre-packaged solutions to many basic technical tasks. In addition to the large library of function built into the basic MATLAB® language, there are many special purpose toolboxes available to help solve complex problems in specific areas.
- **Flexible Compiler:** It is achieved by compiling the MATLAB® programs into a device independent p-code, and then interpreting the p-code instructions at the runtime. Unfortunately, sometimes the resulting programs execute slowly because the MATLAB® code is interpreted rather than compiled.

On the other hand, MATLAB® has one major disadvantage. Due to the fact that it is an interpreted language it can execute more slowly than compiled languages. This problem can be mitigated by properly structuring the MATLAB® program, and by the use of the MATLAB® compiler to compile the final program.

## 2.2 Simulink<sup>®</sup> software

Simulink<sup>®</sup> [29] is a time based software package that is included in MATLAB<sup>®</sup>, and the data can be easily transferred between the programs. It is supported on Unix, Macintosh and Windows environments. Its main task is to solve Ordinary Differential Equations (ODE) numerically, and especially those differential equations that are nonlinear and don't have analytical solution.

The purpose of Simulink<sup>®</sup> is to break the ODE in small time segments and calculate the solution for each segment numerically. Each segment is also called “step size”. Due to the fact that the solution is numerical and not analytical, it's sure that there will be errors, which depend on the step size and the method that is used.

Simulink<sup>®</sup> uses a lot of different methods to solve the equations numerically, such as: Dormand-Prince (ODE5), fourth-order Runge-Kutta (ODE4), Bogacki-Shampine (ODE3), improved Euler (ODE2) and Euler (ODE1). The problem that exists is that the higher the order method is, the slower it is. For that, variable step size solvers are used. When the system's state is getting slower, then the step size can increase, by increasing that way the simulation. On the other hand if the states change rapidly then the step size must be sufficiently small.

By clicking the Simulink<sup>®</sup> icon on the MATLAB<sup>®</sup> toolbar, the Simulink<sup>®</sup> Library Browser appears, as it is shown in the following figure (Fig.2.1).

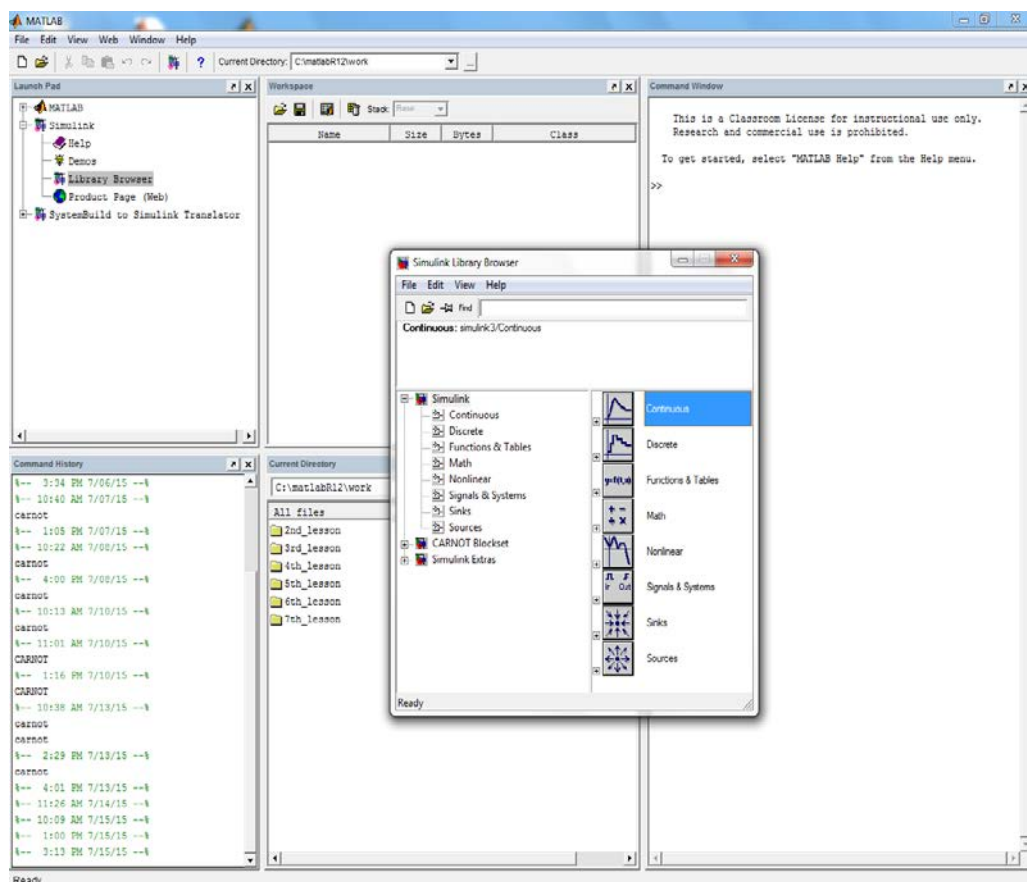

Fig.2.1: MATLAB<sup>®</sup> in five panel desktop layout and the opened window of Simulink<sup>®</sup> Library Browser

The Library Browser displays a tree-structured view of the Simulink<sup>®</sup> block libraries which are installed. As it is shown, there are many libraries and even more sub-libraries, so the user must spend some time in order to familiarize with the libraries and the blocks that each one of them contain.

The most competitive advantage of the Simulink<sup>®</sup> is that it is included in the MATLAB<sup>®</sup> program. Another advantage of Simulink<sup>®</sup> is the ability to take on initial conditions, while when a transfer function is built, the initial conditions are assumed to be zero. Last but not least, as it has already been mentioned above, Simulink<sup>®</sup> has the ability to model a nonlinear system, which a transfer function is unable to do.

On the other hand the main disadvantage of the Simulink<sup>®</sup> is the computation time, in relation to other programs like PSCAD or PowerFactory. Also, with Simulink<sup>®</sup> it is quite difficult to handle large power systems. Finally, as Simulink<sup>®</sup> is included in the MATLAB<sup>®</sup> program, its licence is pretty expensive.

## 2.3 C.A.R.N.O.T. software

The C.A.R.N.O.T. blockset (Conventional And Renewable eNergy systems OpTimization blockset) [30] [31] is a software tool for simulation of thermal systems with conventional and renewable components for the environment of MATLAB®-Simulink®. It is developed by the Solar-Institut Jülich and is available since November 1999. The C.A.R.N.O.T. blockset is organized as modular library similar to the Simulink® standard library. It contains two libraries, the Carnot and the Carsys library, which are described in detail below.

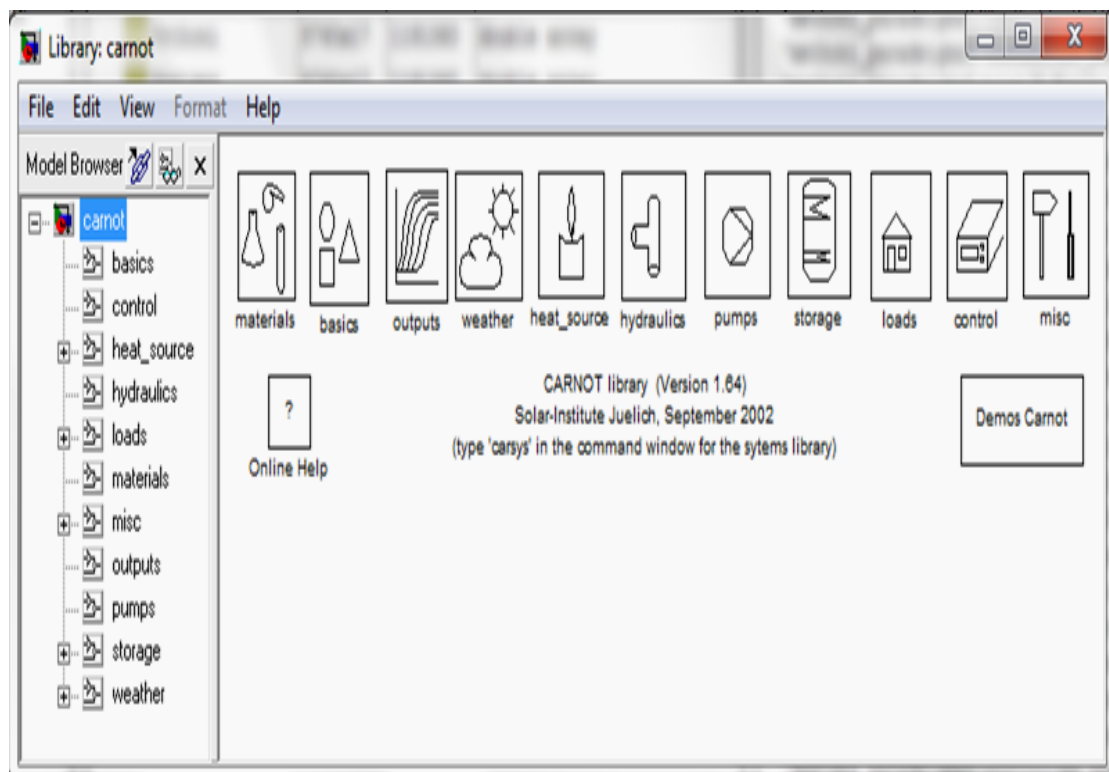

Fig.2.3: Carnot library

The Carnot library, as shown in Fig.2.3, includes 11 different blocksets with respective components in them, in order to facilitate the modeling. As we can see for the Fig.3.3 these blocksets are:

- **Materials:** In this blockset the user can find the material properties of the mostly used fluids (water, air, silicon oil, cotton oil and water with glycol mix) in conventional and solar heating systems. The user has also the ability to change or to add further functions for the fluids.
- **Basics:** It contains all the basic functions of the fluid dynamic values and the characteristic numbers of the fluids, like the Reynolds or the Prandtl number, the velocity, the conversion of the relative humidity to absolute humidity and others.
- **Outputs:** In this specific blockset online visualization and results are encountered. More specifically, the user can find the scope blocks that can be adapted to the data structure of Carnot, energy meter for the displaying of the energy difference between the entering and the exiting of a block and others.

- **Weather:** It comprises basic weather models which are required in a number of blocks.
- **Heat source:** This blockset includes common conventional and renewable heat sources, like flat plate collector, heat exchanger, heat pumps, parabolic trough collector, evacuated tube collector, furnace and others.
- **Hydraulics:** It contains the hydraulic elements that can be found in house heating systems, like pipes, valves and flow diverters.
- **Pumps:** In this blockset there are found 3 different pump models (constant mass flow, user defined characteristic and characteristic of the German manufacturer Wilo) as well as a thermosyphon model.
- **Storage:** The user can find in this blockset different kinds of thermal storages, like water storage (simple storage, multiport storage with internal heat exchangers and combi storage) and ground storage (3D ground storage, U-tube ground storage and surface model).
- **Loads:** It contains the loads: a simple building model, a radiator heating and a floor heating system. It also contains water taps as symbols for user-definable water consumption.
- **Control:** This blockset contains all the necessary components for controlling the systems, like measurement sensors and bang-bang controllers.
- **Misc:** Various elements are comprised in this blockset, like the phase check block, which checks and displays a warning if the phase of the fluid change and the ecology and economy blocks which can be connected to the source blocks.

Further the Carnot library contains the Demos Carnot, where the user can familiarize with the interface, as well as Online Help, where an HTML manual appears with keyword search mechanism in order to facilitate the search process.

The **Carsys library** is similar to the Carnot library but all the components have the parameter sets of the manufacturers. This means that the Carsys library address to more applied and practical use in planning, system design, economic analyses etc. The Carsys library contains only 9 blocksets.

The blocksets are connected to each other with lines, like in the case of Simulink<sup>®</sup>, which are called THV (Thermo-Hydraulic Vector). The THV transfers all the necessary thermal and hydraulic information from block to block. They are practically like physical pipe connections between the components. In case of THV split up, then the calculations are carried out in the next block or blocks, and the THV is reassembled with the processed values.

Except the THV there are also other vectors in order to achieve a physical connection of the data between different blocks. These are: the weather data vector (which transfers all the relevant characteristics of the weather data sets, like direct and diffuse radiation, wind speed and direction, relative humidity, ambient temperature and others), the fuel vector (which is used in the ecology block to calculate data like the ratio of the chemical components, the air

demand etc) and the eco vector (which is used in the economy block to calculate the mass flow of CO<sub>2</sub>, H<sub>2</sub>O, the temperature, the electric power, the thermal power etc).

## 2.4 Meteonorm4 software

Meteonorm4 [32] is a meteorological database software program which contains climatological data for solar engineering applications from all around the world. The program collaborates with more than 8325 weather stations (1600 of which are in Europe, 1900 in Asia, 2625 in North America, 800 in South America, 600 in Africa and 800 in Australia and in Oceania) and 5 geostationary satellites, and its interpolation models deliver the global data with the highest accuracy. In Greece Meteonorm4 has more than 30 weather stations, as it is shown in the following figure (Fig.2.4).



Fig.2.4: Weather stations of Meteonorm4 in Greece

It is used by the biggest companies and research foundations in the world, like Bosch, Siemens, Sharp, Juwi, Fraunhofer and others. It can provide data from a yearly to a monthly and an hourly base, in ASCII files. More precisely from the monthly values (of the station data, the interpolated data or the imported data), Meteonorm4 calculates the hourly values of all the parameters by using a stochastic model. The export of the data can be done with 36 different predefined formats, which cover most of the existing simulation software in solar energy applications.

Meteonorm4 disposes more than 30 parameters which concern the irradiation and the temperature of each region. The most important of them are: the direct and diffuse radiation on the horizontal plane, the global horizontal radiation, the cloud index, the wind direction and speed, the albedo, the precipitation, the relative humidity, the air pressure, the ambient temperature, the emissivity in the horizontal and vertical plane, the height of the sun, the

azimuth of the sun and others. The periods 1961 - 1990 and 2000 - 2009 are available for temperature, humidity, wind speed and precipitation while the periods 1981 - 1990 and 1991 - 2010 for solar radiation.



## Chapter 3-Hotel selection and meteorological data of the area

### 3.1 Selection of the hotel

The hotel of reference in the specific master thesis is the Demis apartments, which is located in Sidari (latitude 39.78 and longitude 19.71), in the northwest side of the island of Corfu in Greece.

The hotel consists of 9 studios apartments and can accommodate 2, 3 or 4 persons. The hotel address not only to couples but to families with children as well. All the studios have a kitchenette with cooking hobs, fridge and electric kettle, air condition, LCD TV and a private bathroom with hairdryer.

The hotel is operational every year only during the summer, from the beginning of May until the end of October. For that reason it does not require space heating but only heating water for domestic use.

As it is shown in the following figure (Fig.3.1) which was taken from the Google maps, the roof tiles of the west block of studios has northeast-southwest orientation, while the roof tiles of the east block of studios has northwest-southeast orientation.



Fig.3.1: Location of the hotel from Google maps

It is known that the solar collectors, in order to have their maximum output (maximization of the incident solar energy), should be put towards south (Fig.3.2), or with deviation  $\pm 35^\circ$  to the east or west, for energy reduction lower than 5 %. Increase of the deviation more than  $\pm 35^\circ$  demands an increase of the absorbing surface of the solar collectors, fact that increases the installation cost and the payback time of the investment. Comparing the Figures 3.1 and 3.2 it is obvious that only in the south side of the west and the east blocks of the studios can the solar collectors be installed. The surface of the solar collectors that is going to be installed

in the roof tiles of the south side must be able to cover the need also and the northwest and northeast studios.

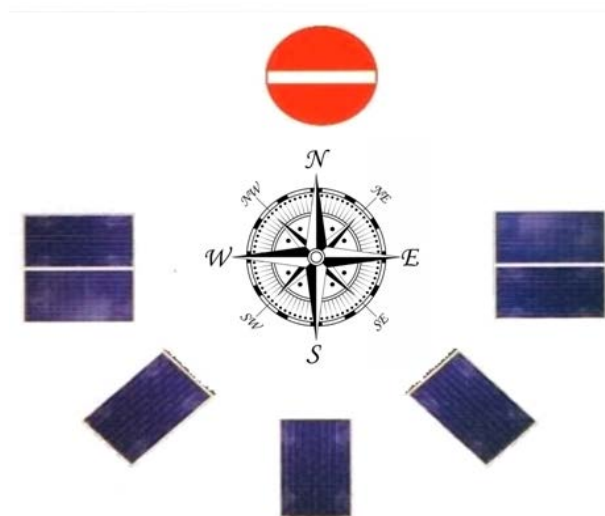

Fig.3.2: Optimum installation of solar collectors

The solar collectors could also be installed on the surrounding ground of the hotel, but in that case the aesthetic harmony of the area would be disturbed, since around the studios there is grass with trees. The surrounding ground is not planned for installation of a solar system in the near future and therefore is not considered as a design site in this thesis.

### 3.2 Climate of Corfu

The climate of Corfu is Mediterranean, with cool summers and mild winters. Corfu has almost the same average annual temperature like Athens, the capital of Greece, although it's located further in the north. The ground of the island is mainly plain (more specifically 63 % of the ground is plain, 35 % is semi-mountainous and 2 % mountainous). The coldest month of the year is January and the warmest month is August. The average temperature of the year is 15.5 °C.

Autumn is much warmer than the spring, because of the south winds. The winter is mild, but sometimes due to the north winds and especially Bora (which comes from the Adriatic Sea), the cold is getting intense, with temperatures that reach  $-5$  °C. If there are no north winds during winter, then south-southwest winds blow, which sometimes exceed in intensity the 8 Beaufort. In spring the temperature begins to rise, although at March there are lots of rains. In summer the temperature does not exceed the 35 °C.

The relative humidity of the island is pretty high, with 77 % from October till February, 61 % from June to August and around 70 % all the other months of the year. The cloud cover is relatively low, like Athens (around 3.9 in the scale from 0 to 10). The snow and the hail are pretty rare even to the highest peak of the island which is the mountain Pantokratoras, with a height of 906 m, at the northeast of Corfu. The annual rainfall height of Corfu is 1183 mm, which is one of the biggest of Greece, and they last from October until March. The extreme rainfalls, in combination with the fertile soil of the island are contributing to the creation of the most interesting flora and fauna of all the islands in Greece.

In the following figure (Fig.3.3) there are illustrated some of the characteristic values on a monthly base, of the island Corfu, like the precipitation (mm), the maximum and minimum temperature (°C), the sea temperature (°C), the average wind speed (Beaufort), the days with frost, the average sunlight hours, the wet days (> 0.1 mm), the average temperature (°C) and the day length (Hours).

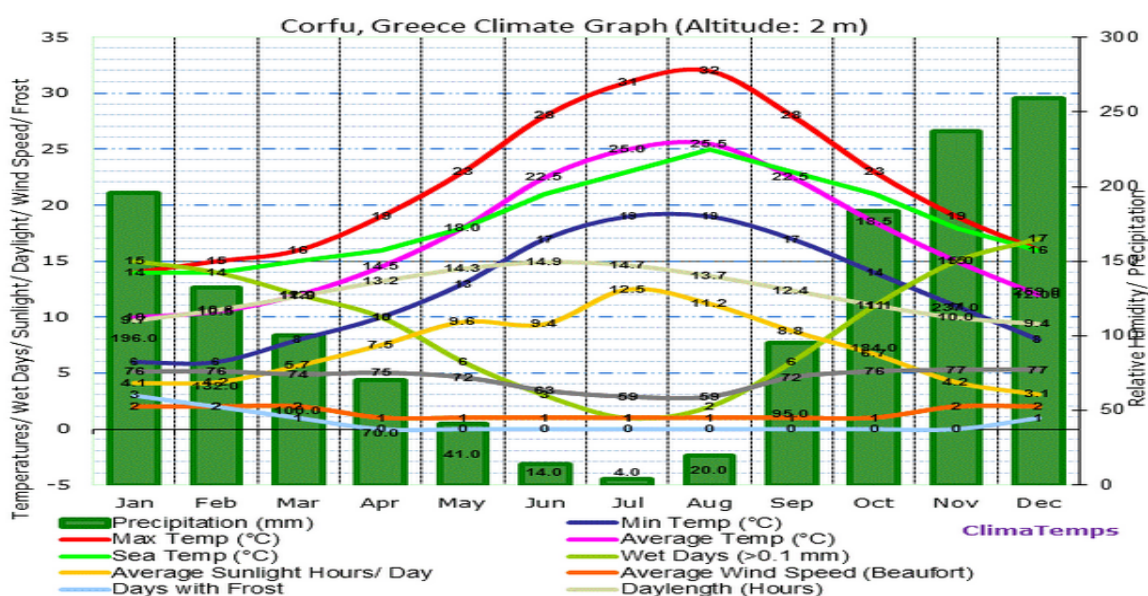

Fig.3.3: Characteristic sizes of the climate in the island of Corfu in Greece [33]

### 3.3 Data and existing system in the hotel

For the collection of information regarding the data and the existing system in the hotel, a questionnaire (which is included in the appendix) was created and was sent to the owner of the hotel. The completed questionnaire provided valuable information which is described in details below.

The hotel is open seasonally, and more specifically, from the beginning of May until the end of October. It consists of two two-bed studios, two three-bed studios and five four-bed studios, which mean that with 100 % occupancy it can accommodate in total 30 persons. During these months of operation, the occupancy of the hotel varies according to the following table (Table 1):

Table 1: Occupancy in persons and percentage, as well as which rooms they occupy

Month	Occupancy in persons	Occupancy in %	2-bed rooms	3-bed rooms	4-bed rooms
January	-	-	-	-	-
February	-	-	-	-	-
March	-	-	-	-	-
April	-	-	-	-	-
May	8.5	28.33	2	1.5	0
June	14	46.67	2	2	1
July	22	73.33	2	2	3
August	30	100.00	2	2	5
September	19	63.33	2	1	3
October	8	26.67	1	2	0
November	-	-	-	-	-
December	-	-	-	-	-

The hot water is used, according to the completed questionnaire, only for the shower and the washbasin that each studio contains and the washbasin that exists in the kitchenette of each room, as the hotel does not have a dining room, laundry of clothes or pool that could also require the consumption of hot water.

Unfortunately the owner of the hotel has a single water flow meter that measures the total amount of water, and thus he could only provide data on the total daily consumption of the hot water.

At this point, it is worth mentioning that the technical guidance 20701 – 1 / 2010 of the Technical Chamber of Greece (T.O.T.E.E.) [34], which gives analytical clarifications of the national parameters for the calculation of the energy efficiency of the buildings and the publication of certificate of energy efficiency, defines the typical daily consumption of hot water (of 50 °C) of different types of buildings (houses, hotels, hospitals and others) for the calculation of the total energy consumption. For a hotel of C class and seasonal operation, the daily consumption of hot water is set to 60 lt / person / day. Having as given the daily consumption per person and the temperature of the hot water, a new table was created (Table 2), which concerns the total daily and monthly consumption of the hotel, in combination with the previous table and the occupancy of the hotel in persons (second column of Table 1).

Table 2: Daily and monthly consumption of hot water of the hotel, according to TOTEE

Month	Days per month	Occupancy in persons	Daily consumption of hot water of 50°C per person according to TOTEE (lt / person / day)	TOTAL daily consumption of hot water of 50°C of the hotel, according to TOTEE (lt / day)	TOTAL MONTHLY consumption of hot water of 50°C of the hotel, according to TOTEE (lt / month)
January	31	-	-	-	-
February	28	-	-	-	-
March	31	-	-	-	-
April	30	-	-	-	-
May	31	8.5	60	510	15810
June	30	14	60	840	25200
July	31	22	60	1320	40920
August	31	30	60	1800	55800
September	30	19	60	1140	34200
October	31	8	60	480	14880
November	30	-	-	-	-
December	31	-	-	-	-

The current system for the covering of the needs in hot water consists of a boiler and a burner, which burns oil, an oil storage tank, a storage water tank and a pump that transfers the hot water from the boiler to the storage tank.

According to the completed questionnaire, the type of the burner is BENTONE ST133K. The thermal power of the burner is 80000 kcal / h. If this number is converted to W, is around 93040 W. But the burner is not working with 100 % efficiency. If an 80 % efficiency of the burner is assumed, then the nominal power of the burner in W is:

$$93040 \text{ W} \cdot 0.8 = 74432 \text{ W}$$

The dimensions of the burner, as long as a picture of it, are shown in the following figure (Fig.3.4).

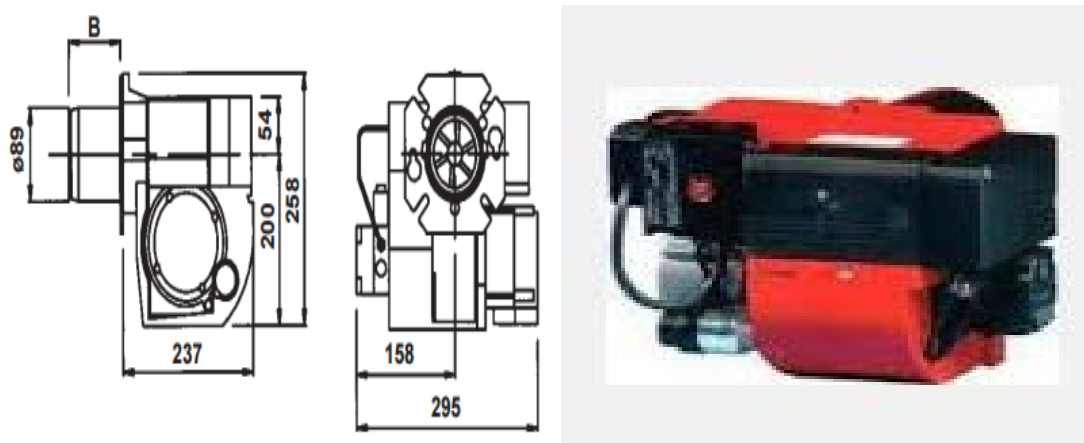

Fig.3.4: Dimensions and picture of the oil burner BENTONE ST133K [35]

The oil storage tank can hold up to 500 lt (0.5 m<sup>3</sup>) of oil. The storage tank of the water is a standing cylinder with dimensions 1.60 m height and 0.60 m in diameter, and it can hold up to

350 lt (0.35 m<sup>3</sup>) of hot water. The pump that transfers the hot water from the boiler to the storage tank has a pressure of 3bar. The mass flow of the water pump is taken by the Law of calorimetry, as follows:

$$Q_b = \dot{m} \cdot C_p \cdot \Delta T \Leftrightarrow \dot{m} = \frac{Q_b}{C_p \cdot \Delta T}$$

where:

$\dot{m}$  is the mass flow of the furnace pump, in m<sup>3</sup> / h

$Q_b$  is the thermal power of the boiler, in kcal / h

$C_p$  is the heat capacity of the water, in kJ / (kg · K)

$\Delta T$  is the difference between the incoming and the outgoing temperature in the tank, and it is equal to 15 °C.

From the above equation, the mass flow of the furnace pump equals to:

$$\dot{m} = 5.33 \frac{\text{m}^3}{\text{h}}$$

But as Table 17 in subchapter 4.4 shows, the program needs the mass flow in kg / s, so the mass flow of the pump that is inserted in the program is:

$$\dot{m} = 5.33 \frac{\text{m}^3}{\text{h}} = \frac{5330 \frac{\text{kg}}{\text{h}}}{3600 \frac{\text{h}}{\text{s}}} \Rightarrow \dot{m} = 1.48 \frac{\text{kg}}{\text{s}} \approx 1.5 \frac{\text{kg}}{\text{s}}$$

The completed questionnaire provides also the peak hours of consumption of the hot water of use, which are shown in the following table (Table 3), as it was filled by the owner of the hotel.

Table 3: Peak hours of consumption of hot water in the hotel

	From	Until
Morning	09:00	11:00
Noon		
Afternoon	18:00	21:00
Evening		

These peak hours were set in the repeating sequence block set of the water tap, in order for the water tap to provide the necessary liters of cold water to the storage tank.

The lengths of both the external and the internal pipes, as well as the bends on 90 ° that were used (Table 7, Table 8, Table 12, Table 13, Table 14, Table 16, Table 19 and Table 21 in subchapter 4.4), were taken approximately, and according to the picture from Google maps (Fig.3.1), as the owner of the hotel was unable to provide the ground plans of the hotel, in order to calculate the exact lengths of the pipes that are required.

Also, through the questionnaire, the height of the east and the west building was found that is equal to 5 m from the ground up to the beginning of the tiles. The tiles have an inclination of  $15^\circ$ , while the solar collectors in order to be effective (according to the general type that says that the optimal inclination of the solar collectors for the summer period is equal to the latitude of the place minus  $15^\circ$ ) must be put with an inclination of  $25^\circ$ .

Since the solar collectors are going to be installed with a different inclination of those of the tiles, this means that the two surfaces are not going to be parallel to each other, and for that reason special supports must be used, which will increase the initial cost of installation.

## Chapter 4-Development of the model with the C.A.R.N.O.T. software

### 4.1 Weather data

The data of the software program Meteonorm4 for the island of Corfu, with latitude  $39^{\circ}37'N$  and longitude  $19^{\circ}55'E$  were used for the development of the hybrid model. This location of the measured weather data is pretty close to the location of the hotel, and therefore it is considered that the sunrise and sunset hours of the Meteonorm4 weather station and the hotel's position are equal.

For the creation of the data file a specific groundwork was made in order to create the appropriate columns of data for the simulation model and also to convert the created file into the form of .dat, which is recognizable by the software program C.A.R.N.O.T.

Since the hotel is operating only seasonal, in the following figures below the direct solar radiation (Fig.4.1), the diffuse solar radiation (Fig.4.2), the ambient temperature (Fig.4.3) and the wind speed (Fig.4.4) only for the operational months of the hotel are shown. As Figure 4.1 shows, the direct solar radiation for 1 May until 31 October varies from  $0 \text{ W} / \text{m}^2$  up to  $970 \text{ W} / \text{m}^2$ , with an average value of  $114.6 \text{ W} / \text{m}^2$ . From Figure 4.2, the diffuse solar radiation varies from  $0 \text{ W} / \text{m}^2$  up to  $486 \text{ W} / \text{m}^2$ , with average value  $98.9 \text{ W} / \text{m}^2$ . In Figure 4.3 the ambient temperature from 1 May until 31 October varies from  $8.1 \text{ }^{\circ}\text{C}$  up to  $37.4 \text{ }^{\circ}\text{C}$ , with an average temperature of  $22.8 \text{ }^{\circ}\text{C}$ . Finally, in Figure 4.4, the wind speed for the operational months of the hotel varies from  $0 \text{ m} / \text{s}$  up to  $14.9 \text{ m} / \text{s}$ , with an average value of wind speed the  $1.9 \text{ m} / \text{s}$ .

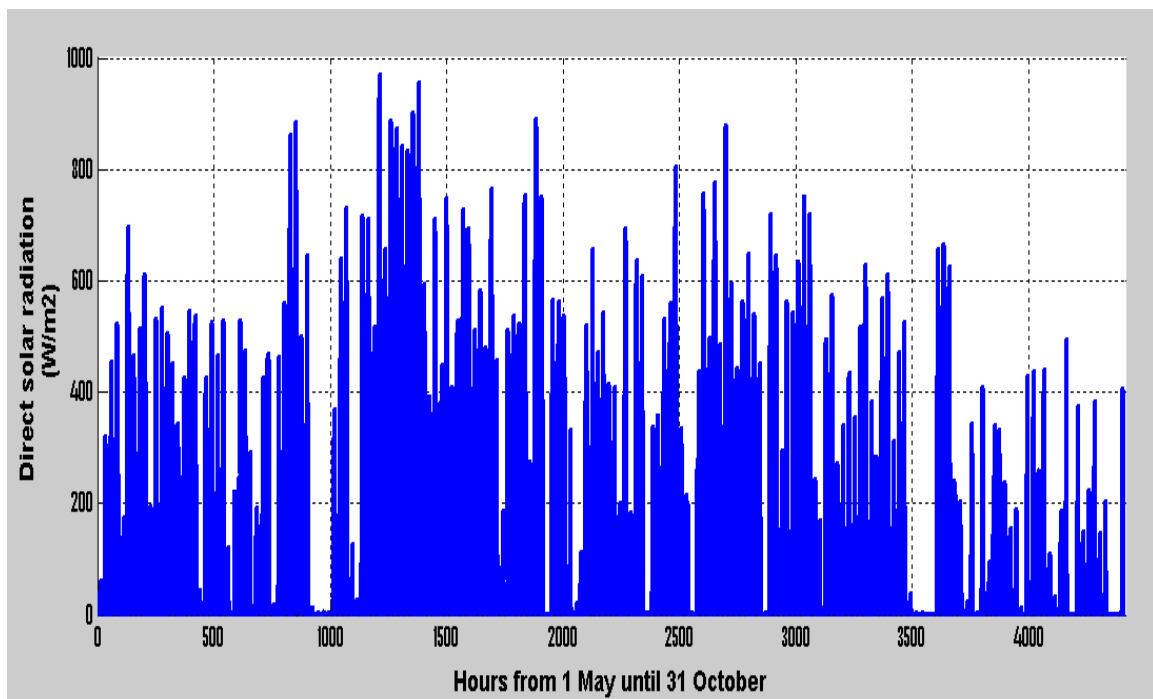

Fig.4.1: Diagram of the direct solar radiation on the horizontal plane in  $\text{W} / \text{m}^2$  in an hourly base from 1 May until 31 October, for the island of Corfu from Meteonorm4



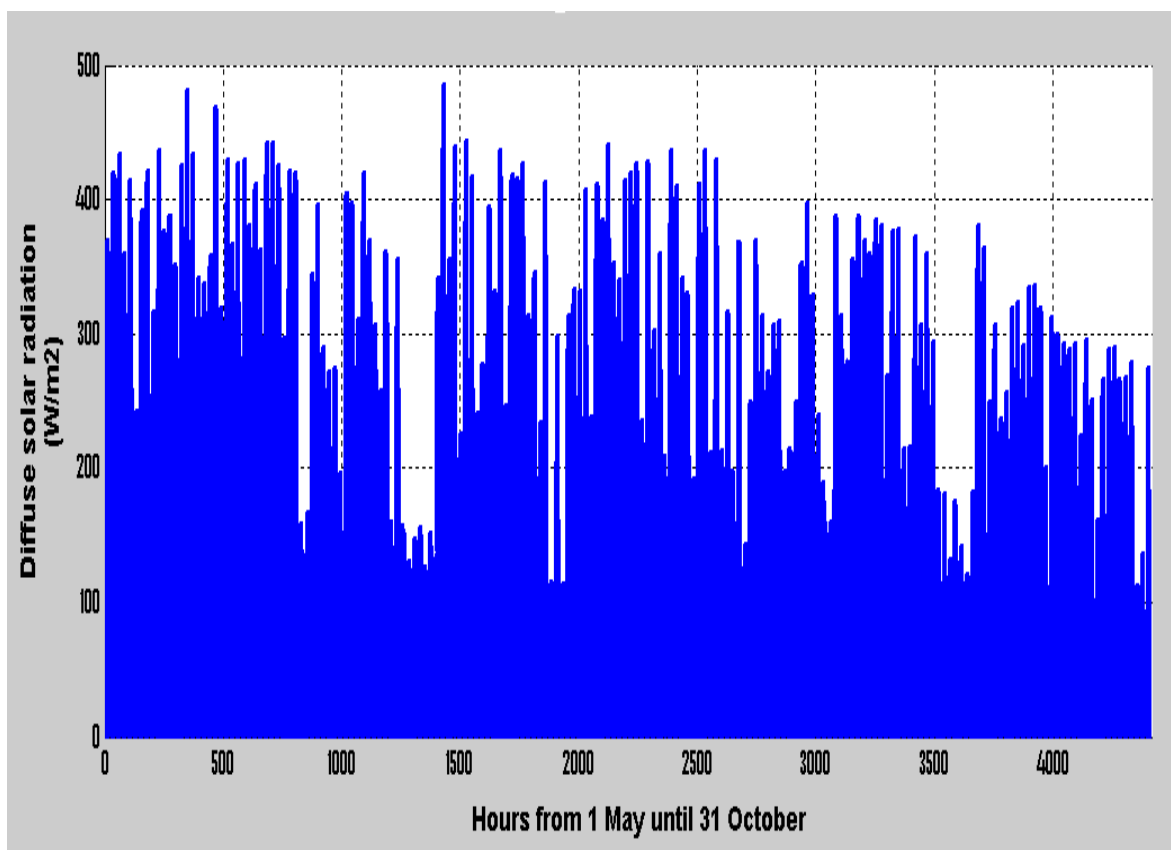

Fig.4.2: Diagram of the diffuse solar radiation on the horizontal plane in  $W / m^2$  in an hourly base from 1 May until 31 October, for the island of Corfu from Meteonorm4

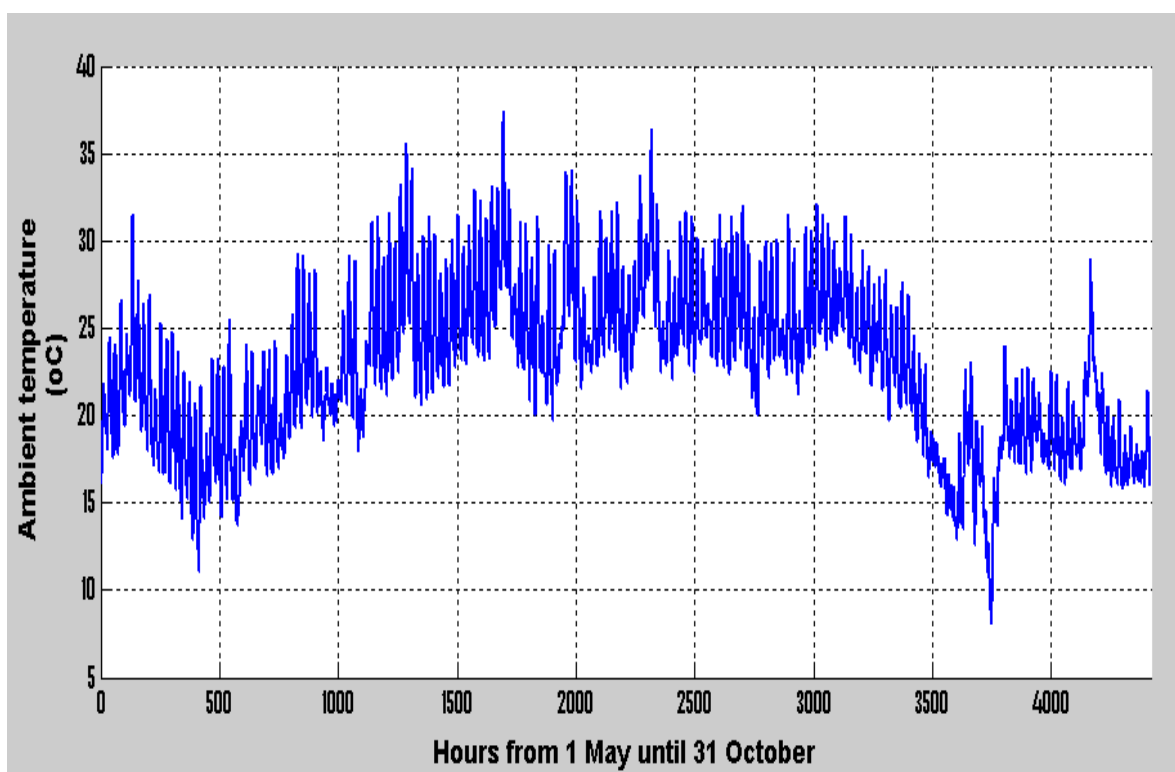

Fig.4.3: Diagram of the ambient temperature in  $^{\circ}C$  in an hourly base from 1 May until 31 October, for the island of Corfu from Meteonorm4

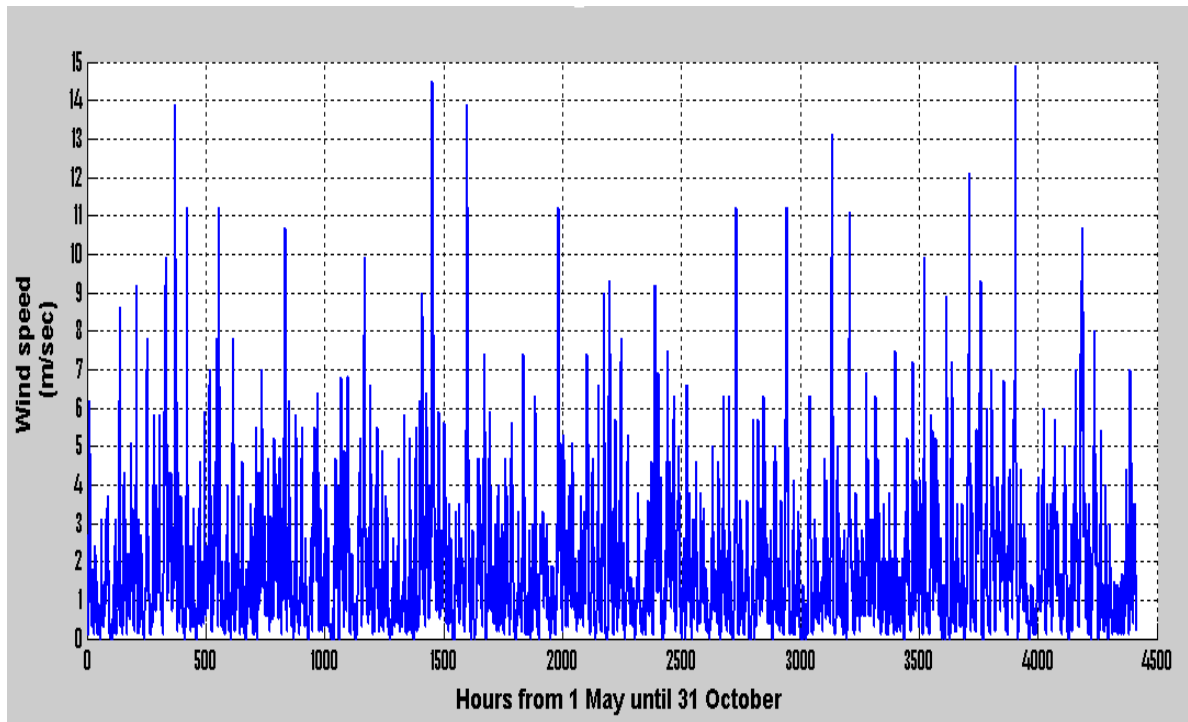

Fig.4.4: Diagram of the wind speed in m / s in an hourly base from 1 May until 31 October, for the island of Corfu from Meteonorm4

## 4.2 Description of the cycles of the model

The figure below (Fig.4.5) shows the hybrid system of the flat plate collectors and the boiler for the covering of the needs in hot water.

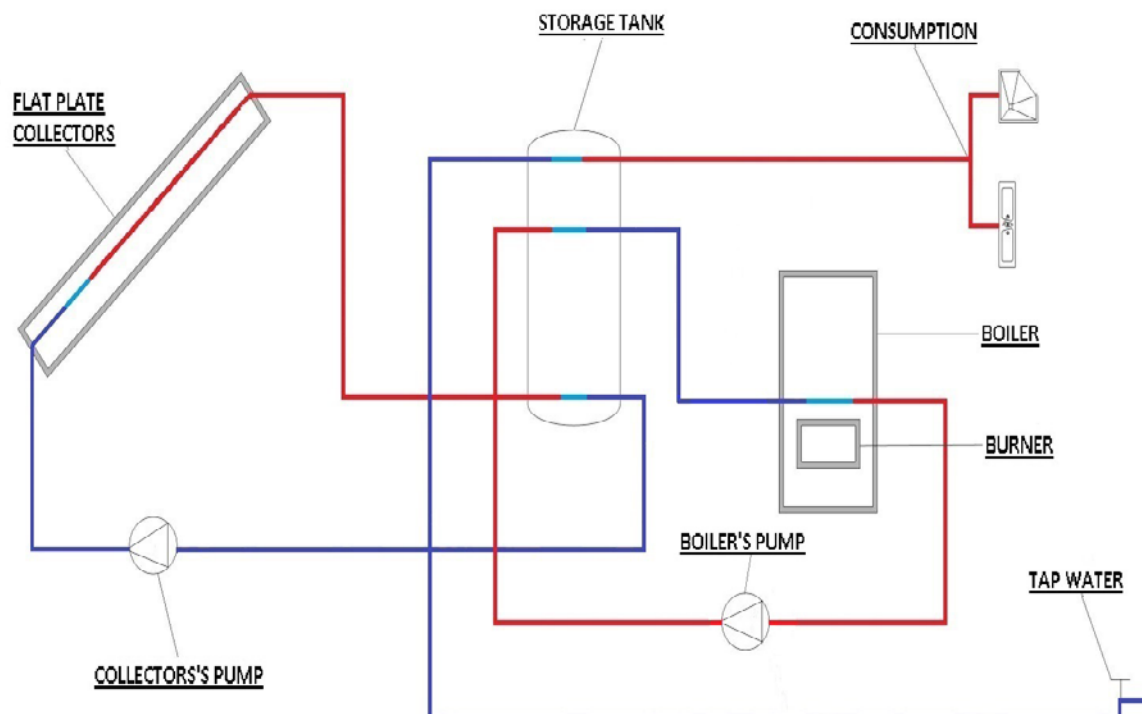

Fig.4.5: Hybrid system of flat plate collectors and a boiler

The hybrid system consists of three different cycles: the first is the charging closed cycle of the flat plate collectors, the second one in the charging closed cycle of the boiler and the burner and the third one is the discharging open cycle of the consumer.

In the first charging closed cycle of the flat plate collectors, the cold water mix (which consists of 60 % water and 40 % glycerol, for anti-freezing reasons) is being pumped from the storage tank, with the use of the collectors' pump (which is located in a protected close room along with the storage tank). The water mix, by continuing through the inside and outside pipes (where the heat losses by conduction to the environment, by conduction in axial direction and the pressure drop in the pipe connection between the elements is calculated), it ends at the entrance of the solar collectors. There it circulates inside the pipes of the flat plate collectors, and absorbs the solar radiation, thereby increasing its temperature, and then comes out from the solar collectors. Continuously, the hot water mix is led through the pipes back to the storage tank, and through the phenomenon of conduction it gives its heat to the water, resulting on the one hand in the increase of water temperature and on the other hand to the reduction of the water mix temperature, which is coming out from the storage tank.

In the second charging closed cycle of the boiler and the burner, the cold water is being led to the boiler. The burner, which burns oil and produces heat, warms the cold water that comes out of the storage tank. The hot water comes out of the boiler, and is being led back to the

storage tank with the help of the boiler's pump, where it gives away its heat to the water, and it comes cold out of the storage tank cold.

In the third discharging open cycle, the cold water from the water tap is being sent into the storage tank, where it increases its temperature by absorbing the heat from the water of the two other closed cycles, and it comes out from the storage tank, in order to be transferred to the rooms of the hotel for consumption.

### 4.3 Creation of the model in C.A.R.N.O.T. program

The hybrid system of Fig.4.5 was implemented in the C.A.R.N.O.T. program as it is shown in the following figure (Fig.4.6).

The ambient temperature of the outside pipes is taken by the hourly data, as they were extracted by the Meteonorm4 program, while the temperatures of the blocks, such as the internal pipes, the storage tank and the furnace, that are protected from the external conditions that prevail in the area, take their values from a different block (called "T<sub>amb</sub> inside the room"). This block contains the monthly temperatures of the internal areas, as they were determined by the Technical Chamber of Greece (T.O.T.E.E.) [36], for a hotel of seasonal operation. More specifically, for a hotel of seasonal summer operation during the winter period the internal temperature is set to 20 °C, while during the summer period this temperature is equal to 26 °C.

Just before the water tap there is a multiplication of the repeating sequence (which contains the peak hours of consumption, as they were acquired by the questionnaire), with the occupancy of the hotel for each month of operation. For each operation day of the hotel, the total daily mass flow of cold water that enters the storage tank is chosen in order to match column 5 of Table 2, in subchapter 3.3.

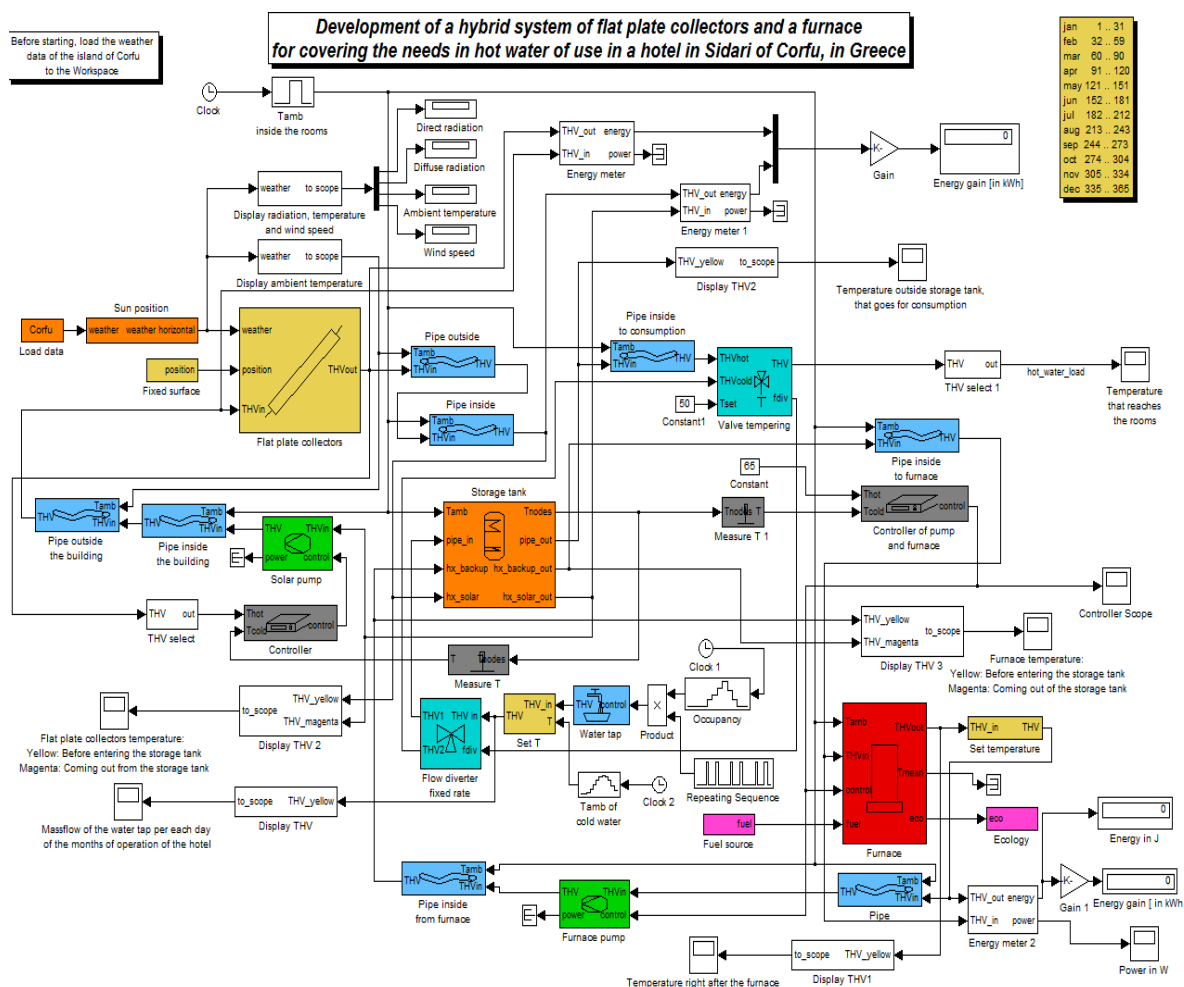

Fig.4.6: C.A.R.N.O.T simulation program of the hybrid system

The ambient temperature of the water in the water tap is not the same for each month. For that reason, after the water tap block, there are two blocks, the  $T_{amb}$  of cold water and the Set T blocks. The  $T_{amb}$  of cold water block includes the ambient temperature of the water supply network, for each month of the year, as it was acquired by the ELOT 1291 (National Organization for Standardization in Greece) [37], and it is described in detail by the Technical Chamber of Greece (T.O.T.E.E.) [38]. According to that table, and for the island of Corfu, the following figure (Fig.4.7) was created, in order to describe the ambient monthly temperature of the water supply network.

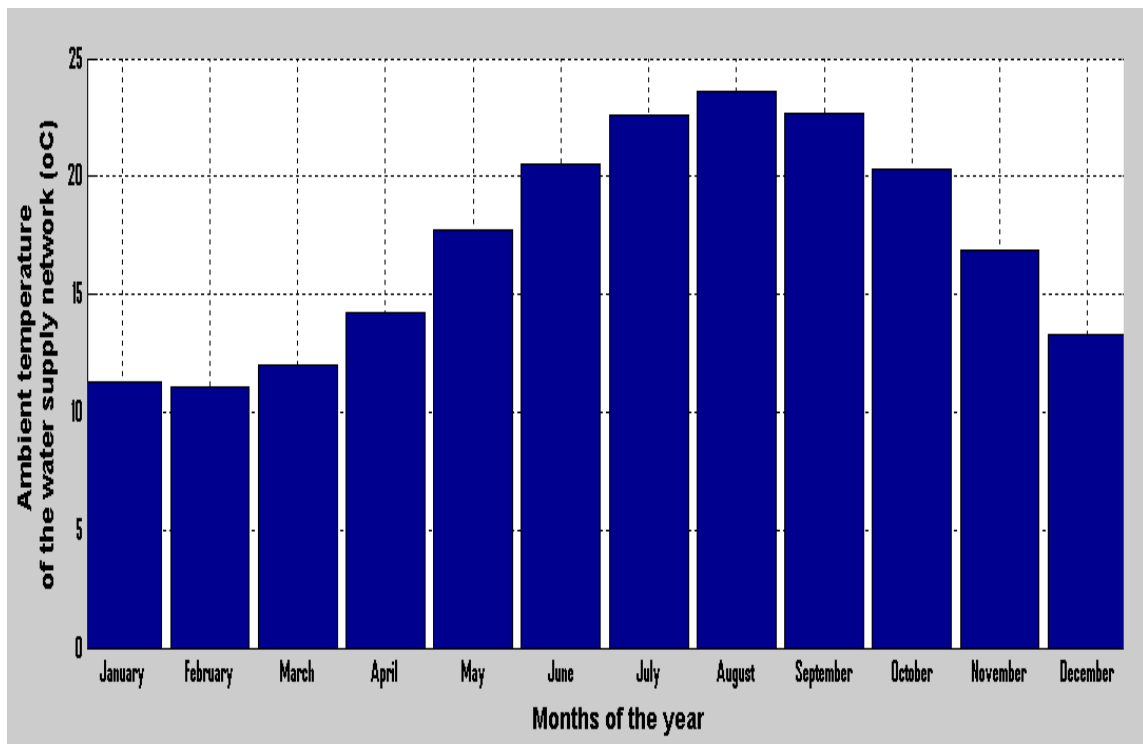

Fig.4.7: Ambient monthly temperature of the water supply network according to ELOT 1291

The Set T block is setting each month the appropriate temperature of the cold water to the open cycle of consumption.

## 4.4 Block parameters of the model

After the creation of the weather data, which was analyzed in subchapter 4.1, the following block according to Figure 4.6 is the sun position, and the table that describes its parameters is shown below in Table 4. This block has the parameters of the geographical longitude and the geographical latitude of the hotel, as long as the longitude of the time zone. The latitude and longitude of the hotel were also mentioned in subchapter 3.1 (latitude 39.78 and longitude 19.71). As for the time zone, Greece and Corfu belong to the EET + 2 (Eastern European Time zone + 2), and each hour equals to 15 °, that is why the parameter of the time zone is set to – 30 ° (since if it is east, the program requires negative value).

Table 4: Parameters of the sun position block

Parameter	Value	Unit
Geographical longitude (east negative)	-(19+71/60)	degrees
Geographical latitude (north positive)	39+78/60	degrees
Longitude of timezone (east negative)	-30	degrees

The fixed surface block is the second input to the flat plate collectors block. In the following table (Table 5) all the parameters of this block are presented. These parameters are: the collector slope, which as it was discussed in the subchapter 3.3, it must be 25 ° in order to have the best performance and exploit the direct solar radiation that impinges on the flat plate collectors, the collector azimuth which is – 25 °, since the collectors are going to be installed in the south side of the west block of studios which is facing southeast and finally the collector rotation angle, which is set to 0 since the solar collectors are going to be installed with no rotation around the longitudinal axis.

Table 5: Parameters of the fixed surface block

Parameter	Value	Unit
Collector slope (0°=horizontal)	25	degrees
Collector azimuth (0°=south, -90° = east)	-25	degrees
Collector rotation angle	0	degrees

The following block in the model is the flat plate collectors. In this block, almost all the parameters were imported with the default values of the program C.A.R.N.O.T., as the most important parameter of this block is the surface of the collectors. The calculation of the total surface of the flat plate collectors needed was made according to Volker Quaschnig's book [39], and according to the following equation:

$$A_c \approx \frac{SD}{n_{KN}} \cdot \frac{Q_N}{H_{solar}}$$

where:

$A_c$  is the surface of the flat plate collectors, in  $m^2$

SD is the coverage ratio of the flat plate collectors, in %

$n_{KN}$  is the average yield of the collector circuit, in %

$Q_N$  is the half-year heat demand, in kWh

$H_{\text{solar}}$  is the solar radiation of the semester of operation of the hotel, in kWh / m<sup>2</sup>

According to T.O.T.E.E. [40], the minimum coverage of the flat plate collectors SD, is set to 60 %.

The half-year heat demand  $Q_N$  is given by the equation:

$$Q_N = D \cdot P \cdot Q_{\text{person}}$$

where:

$Q_N$  is the half-year heat demand, in kWh

$D$  is the number of operation days for the semester, equal to 184

$P$  are the persons that the hotel can accommodate with 100 % occupancy, equal to 30

$Q_{\text{person}}$  is the demand of hot water per person and per day, equal to 1.85 kWh

By replacing the numbers to the above equation, the half-year heat demand  $Q_N$  is:

$$Q_N = 10212 \text{ kWh}$$

According to Meteonorm4, the solar radiation of the semester of operation of the hotel is 945 kWh / m<sup>2</sup>.

By replacing all these numbers, in the equation of the surface of the flat plate collectors:

$$A_c \approx \frac{SD}{n_{KN}} \cdot \frac{Q_N}{H_{\text{solar}}} \Rightarrow A_c \approx \frac{60 \%}{30 \%} \cdot \frac{10212 \text{ kWh}}{945 \frac{\text{kWh}}{\text{m}^2}} \Rightarrow A_c \approx 22 \text{ m}^2$$

The following table (Table 6) shows all the parameters of the flat plate collectors block.

Table 6: Parameters of the flat plate collectors block

Parameter	Value	Unit
Collector surface (aperture)	22	m <sup>2</sup>
Optical efficiency	0.8	-
Linear heat loss coefficient	3.5	W/(m <sup>2</sup> *K)
Quadratic heat loss coefficient	0.02	W/(m*K) <sup>2</sup>
Radiative loss coefficient	0	W/(m <sup>2</sup> *K)
Wind dependent heat loss	0	W/(m <sup>2</sup> *K*m/s)
Length between inlet and outlet	0	m
Effective heat capacity of collector	1e <sup>4</sup>	J/(m <sup>2</sup> *K)
Initial temperature	20	°C
Number of nodes	5	-

After the block of the flat plate collectors, and according to the first charging closed cycle which was described in subchapter 4.2, the hot water enters the outside and the inside pipes, in order to be transferred to the storage tank. Table 7 and Table 8 show all the parameters that were used in the outside and inside pipes respectively. The lengths of these pipes, as long as the numbers of the 90 ° bends of the pipes, were taken approximately. All the other values are equal to the default values of the C.A.R.N.O.T. program.



Table 7: Parameters of the pipe outside block

Parameter	Value	Unit
Diameter	0.02	m
Length of pipe	20	m
Heat loss coefficient	1	W/(m <sup>2</sup> *K)
Effective conductivity in the pipe	0	W/(m*K)
Capacity of pipewall per length	1000	J/(m*K)
Initial temperature	20	°C
Number of nodes	25	-
Roughness of pipe	0.04*1e <sup>-3</sup>	m
Number of 90° bends (45° = 0.667)	4	-
Height, + for outlet above (0 for pump systems)	0	m

Table 8: Parameters of the pipe inside block

Parameter	Value	Unit
Diameter	0.02	m
Length of pipe	4	m
Heat loss coefficient	1	W/(m <sup>2</sup> *K)
Effective conductivity in the pipe	0	W/(m*K)
Capacity of pipewall per length	1000	J/(m*K)
Initial temperature	20	°C
Number of nodes	25	-
Roughness of pipe	0.04*1e <sup>-3</sup>	m
Number of 90° bends (45° = 0.667)	4	-
Height, + for outlet above (0 for pump systems)	0	m

The parameters of the storage tank are shown in Table 9. The first 3 parameters of Table 9 were acquired according to the completed questionnaire, while the other values were taken with the preselected values.

Table 9: Parameters of the storage tank block

Parameter	Value	Unit
Diameter	0.6	m
Volume	0.35	m <sup>3</sup>
Position	standing cylinder	-
Heat loss coefficient wall	0.6	W/(m <sup>2</sup> *K)
Heat loss coefficient bottom	1.1	W/(m <sup>2</sup> *K)
Effective axial conductivity	1.43	W/(m <sup>2</sup> *K)
Initial temperature	25	°C

The cold water of the first closed cycle, comes out of the storage tank, and through the solar pump is led back to the entrance of the flat plate collectors. In the solar pump the mass flow of the fluid that circulates in the system, the pressure of the whole system and the type of fluid that circulates are set. All the other values are taken with the preselected values of the program.

The mass flow of the solar pump was selected according to Dr. S.Kaplani's book [41] where the optimum mass flow in the system of collectors-storage tank-collectors is chosen to

0.015 lt / s of each m<sup>2</sup> of collector's surface. By calculating this number with the surface of the flat plate collectors, the mass flow of the solar pump is 0.015 · 22, as it is shown in the following table (Table 10).

Table 10: Parameters of the solar pump block

Parameter	Value	Unit
Massflow rate	0.015*22	kg/s
Fluid	water_glycol_mix	-
Percentage of fluid mix [0...1]	0.4	-
Diameter at in- and outlet	0.02	m
Electric power consumption	100	W
System pressure	2e <sup>5</sup>	Pa
Capacity of pump	100	J/K
Initial temperature	20	°C

The solar pump is connected to the controller block. The controller takes the temperature of the hot water mix which comes out from the flat plate collectors, and compares it with the temperature of the cold water mix (which is taken at the position 0 from the bottom of the tank) that comes out from the storage tank. If the difference of these two temperatures exceeds a specific value, which is set in the parameters of the block, then the controller gives the order to the pump to start work. The parameters of the controller block are shown in Table 11.

Table 11: Parameters of the controller block

Parameter	Value	Unit
Delta T -on	10	K
Delta T -off	0	K
Maximum temperature	95	°C

Their parameters of the inside and the outside pipes are shown in Table 12 and Table 13 respectively.

Table 12: Parameters of the pipe inside the building block

Parameter	Value	Unit
Diameter	0.02	m
Length of pipe	4	m
Heat loss coefficient	1	W/(m <sup>2</sup> *K)
Effective conductivity in the pipe	0	W/(m*K)
Capacity of pipewall per length	1000	J/(m*K)
Initial temperature	20	°C
Number of nodes	25	-
Roughness of pipe	0.04*1e <sup>-3</sup>	m
Number of 90° bends (45° = 0.667)	4	-
Height, + for outlet above (0 for pump systems)	0	m

Table 13: Parameters of the pipe outside the building block

Parameter	Value	Unit
Diameter	0.02	m
Length of pipe	20	m
Heat loss coefficient	1	W/(m <sup>2</sup> *K)
Effective conductivity in the pipe	0	W/(m*K)
Capacity of pipewall per length	1000	J/(m*K)
Initial temperature	20	°C
Number of nodes	25	-
Roughness of pipe	0.04*1e <sup>-3</sup>	m
Number of 90° bends (45° = 0.667)	4	-
Height, + for outlet above (0 for pump systems)	0	m

In the second closed charging cycle, the cold water after the storage tank is being led to the furnace, with the help of the pipe inside to furnace block, which has the parameters as they are shown in Table 14.

Table 14: Parameters of the pipe inside to furnace block

Parameter	Value	Unit
Diameter	0.02	m
Length of pipe	1	m
Heat loss coefficient	1	W/(m <sup>2</sup> *K)
Effective conductivity in the pipe	0	W/(m*K)
Capacity of pipewall per length	1000	J/(m*K)
Initial temperature	20	°C
Number of nodes	25	-
Roughness of pipe	0.04*1e <sup>-3</sup>	m
Number of 90° bends (45° = 0.667)	0	-
Height, + for outlet above (0 for pump systems)	0	m

When the cold water enters the furnace, it increases its temperature, as it passes through the burner. The most important parameter of the furnace block is its nominal power, which was described in subchapter 3.3. All the other values of the furnace block, which is shown in Table 15, were taken with the preselected values, except the volume of the boiler, which was extracted from the completed questionnaire.

Table 15: Parameters of the furnace block

Parameter	Value	Unit
Nominal power	74432	W
Heat loss coefficient	60	W/K
Pressure drop linear in massflow	20	Pa*s/kg
Pressure drop quadratic in massflow	1000	Pa*s <sup>2</sup> /kg <sup>2</sup>
Volume of the boiler	0.5	m <sup>3</sup>
Initial temperature	20	°C
Number of nodes	1	-

The hot water that comes out from the furnace cannot exceed 95 °C, and therefore it is set to this value in the set temperature block.

All the parameters of the pipe block are presented in Table 16.

Table 16: Parameters of the pipe inside to furnace block

Parameter	Value	Unit
Diameter	0.02	m
Length of pipe	0.5	m
Heat loss coefficient	1	W/(m <sup>2</sup> *K)
Effective conductivity in the pipe	0	W/(m*K)
Capacity of pipewall per length	1000	J/(m*K)
Initial temperature	20	°C
Number of nodes	25	-
Roughness of pipe	0.04*1e <sup>-3</sup>	m
Number of 90° bends (45° = 0.667)	0	-
Height, + for outlet above (0 for pump systems)	0	m

Right after the pipe, the hot water enters the furnace pump. Except the mass flow and the type of the fluid, all the other values are taken with the preselected values of the program C.A.R.N.O.T. The mass flow of the furnace pump was calculated in subchapter 3.3. The parameters of the furnace pump are shown in Table 17.

Table 17: Parameters of the furnace pump block

Parameter	Value	Unit
Massflow rate	1.5	kg/s
Fluid	water	-
Percentage of fluid mix [0....1]	0	-
Diameter at in- and outlet	0.02	m
Electric power consumption	100	W
System pressure	3	bar
Capacity of pump	100	J/K
Initial temperature	20	°C

The furnace pump is connected to the controller of the pump and the furnace block. The controller takes the temperature of the cold water (which is taken at the position 0.7 from the bottom of the tank) that comes out of the storage tank and compares it with the temperature of 65 °C, which is the maximum temperature of the hot water that can reach the storage tank, when only the furnace is working. If their difference exceeds a temperature, which is set in the parameters of the block, then the controller gives the order to the pump and the furnace to start to work. The parameters of the controller of the pump and the furnace are presented in Table 18.

Table 18: Parameters of the controller of pump and furnace block

Parameter	Value	Unit
Delta T -on	20	K
Delta T -off	0	K
Maximum temperature	65.5	°C

The parameters of the pipe inside after furnace block are shown in Table 19.

Table 19: Parameters of the pipe inside after furnace block

Parameter	Value	Unit
Diameter	0.02	m
Length of pipe	1	m
Heat loss coefficient	1	W/(m <sup>2</sup> *K)
Effective conductivity in the pipe	0	W/(m*K)
Capacity of pipewall per length	1000	J/(m*K)
Initial temperature	20	°C
Number of nodes	25	-
Roughness of pipe	0.04*1e <sup>-3</sup>	m
Number of 90° bends (45° = 0.667)	0	-
Height, + for outlet above (0 for pump systems)	0	m

In the discharging cycle of the water tap, there is at the beginning, and before the water tap, a multiplication between the monthly occupancy of the hotel, and the peak hours of the consumption of hot water. In this way, the system is supplied with the necessary amount of water, as it was obtained from Table 2, and concerns the daily and the monthly consumption of hot water. The water tap block contains the following parameters, as presented in Table 20.

Table 20: Parameters of the water tap block

Parameter	Value	Unit
Temperature	20	°C
Massflow	0.1	kg/s
Fluid	water	-
Percentage of fluid mix [0...1]	0	-
Diameter at outlet	0.02	m
System pressure	2e <sup>5</sup>	Pa

Afterwards, as it is already mentioned in sub chapter 4.3, the cold water gets its ambient temperature, which differs for each month, from the blocks of Set T and T<sub>amb</sub> of cold water.

All the amount of cold water enters the flow diverter fixed rate block, which is connected through the f<sub>div</sub> to the valve tempering block. In the flow diverter the total amount of cold water is separated. Part of it goes to the storage tank in order to heat it up, and the remaining amount enters the valve tempering as cold water. In this way, the hot water is mixed with the cold water, and by setting the temperature to 50 °C, it reaches the rooms of the hotel.

Just before the valve tempering block is the internal pipe which leads the hot water for consumption and in the C.A.R.N.O.T. program is described as pipe inside to consumption block. This block contains the total amount of length of the piping, in order to cover the 2 blocks of studios. The corresponding parameters are presented in Table 21.

Table 21: Parameters of the pipe inside to consumption block

Parameter	Value	Unit
Diameter	0.02	m
Length of pipe	40	m
Heat loss coefficient	1	W/(m <sup>2</sup> *K)
Effective conductivity in the pipe	0	W/(m*K)
Capacity of pipewall per length	1000	J/(m*K)
Initial temperature	20	°C
Number of nodes	25	-
Roughness of pipe	0.04*1e <sup>-3</sup>	m
Number of 90° bends (45° = 0.667)	4	-
Height, + for outlet above (0 for pump systems)	0	m

## Chapter 5-Simulation results

### 5.1 Simulation results for the existing system of the oil burner (without collectors)

The existing burner of the hotel burns oil as a fuel. The most important fuel elements are carbon and hydrogen, and most fuels consist of these, and sometimes a small amount of sulfur. Fuel may contain some oxygen and small quantities of incombustibles. The **ultimate chemical analysis** can determine the mass percentage of carbon (C), Hydrogen (H), Oxygen (O), Nitrogen (N), Sulfur (S), ash and water in a fuel. In Table 5.5 [42] the ultimate analysis is described, as well as the Gross Calorific Value (GCV) and the Net Calorific Value (NCV) (described in subchapter 1.3.2), of some liquid fuels. From that table, and for light fuel oil which is appropriate for heating oil, the ultimate analysis provides the necessary data of mass fraction of the fuel, as they are shown in the following table (Table 22):

Table 22: Mass fraction of light fuel oil

Name of substance	
Carbon	0.834
Hydrogen	0.117
Sulfur	0.040
Nitrogen	0.0
Oxygen	0.0
Moisture	0.0
Ash	0.09

The Gross Calorific Value (GCV), as it was calculated, is 44290 KJ / kg and the Net Calorific Value (NCV) is 41669 KJ / kg.

All the prices of liquid fuels are recorded on the Ministry of Development and Competitiveness in Greece [43]. Unfortunately, for the heating oil there exist no values for the consumption and the price from 30 April until 15 October of each year. From the weekly bulletin of review of the fuel prices [44] published in 24 April 2015, and for the prefecture of Corfu, the mean value of heating oil, with VAT (Value Added Tax), was 0.965 €/ lt. Due to the lack of more recent data, this is the final price of the heating oil which is inserted on the program, for the extraction of results.

According to the European Committee, detailed information about the weekly heating oil prices with and without the taxes in the 28 EU countries are presented in the following two figures (Fig.5.1 and Fig 5.2 respectively).

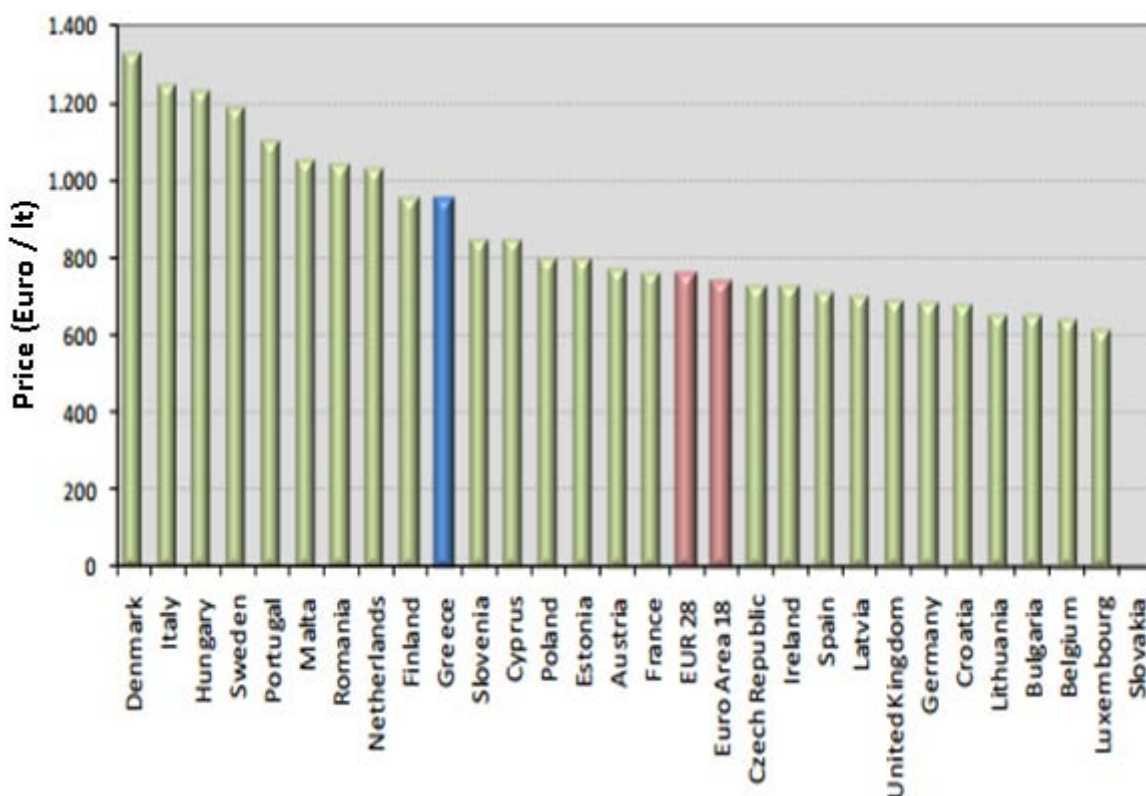

Fig.5.1: Weekly heating oil prices with taxes in the 28 EU countries

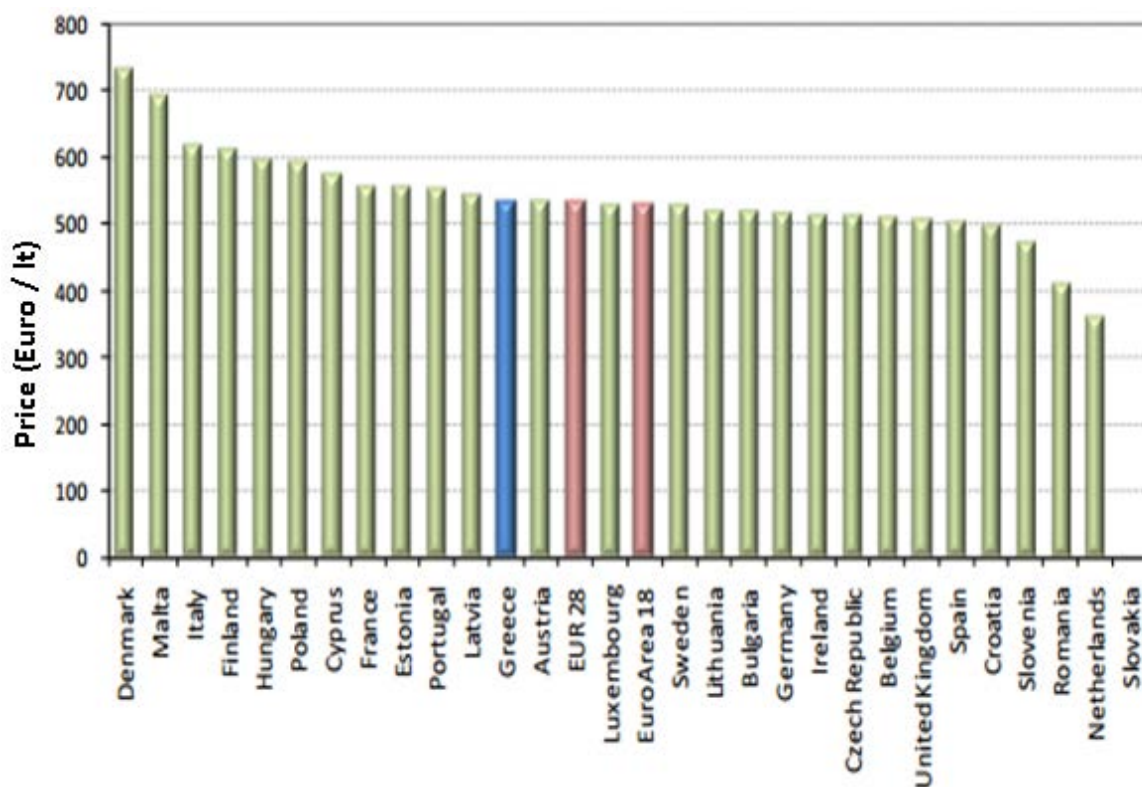

Fig.5.2: Weekly heating oil prices without the taxes in the 28 EU countries

The condensation temperature for light fuel oil was taken equal to 50 °C [45]. Table 23 presents the parameters of the fuel source block, which is connected to the furnace.



Table 23: Parameters of the fuel source block

Parameter	Value	Unit
Type of fuel	fluid	-
Temperature	20	°C
Stoichiometric air demand	1	kg/kg
Pressure	1,00E+05	Pa
Heat without/with condensation	4.167e <sup>7</sup> 4.429e <sup>7</sup>	J/kg
Condensation temperature	50	°C
Price of fuel per kg	0.965	€
Mass fraction [H C O S N H <sub>2</sub> O]	0.117 0.834 0 0.040 0 0	-

In the output of the furnace there is another block that is worth examining, the block of ecology. This block presents all the characteristics that concern the operation of the oil burner (furnace).

By running the simulation model of Fig.4.6 only for the existing system of oil burner of the hotel, and for the whole period of operation from 1 May until 31 October, Table 24 is exported which concerns: the mass of the fuel which was burned during the period of operation of the furnace, the thermal and electric energy that it produced, the fuel cost in euro and the mass production of several different chemical compounds, like H<sub>2</sub>O, CO<sub>2</sub>, O<sub>2</sub>, SO<sub>2</sub>, N<sub>2</sub>, NO<sub>x</sub>, CO and C<sub>x</sub>H<sub>y</sub>.

Table 24: Look under mask in the ecology block

Parameter	Value	Unit
Mass of fuel	1083.5	kg
Thermal energy	45.2	GJ
Electric energy	0	J
Fuel costs	1045.4	euro
Mass of produced H <sub>2</sub> O	1141	kg
Mass of produced CO <sub>2</sub>	3316.1	kg
Mass of produced O <sub>2</sub>	0	kg
Mass of produced SO <sub>2</sub>	86.7	kg
Mass of produced N <sub>2</sub>	0	kg
Mass of produced NO <sub>x</sub>	0	kg
Mass of produced CO	0	kg
Mass of produced C <sub>x</sub> H <sub>y</sub>	0	kg

By running the simulation model for each month of operation of the hotel separately, the following table (Table 25) was created:

Table 25: Oil furnace consumption for each month of operation separately

Parameter	May	June	July	August	September	October	Unit
Mass of fuel	118.8	156.9	226.5	286.9	190.3	104.1	kg
Thermal energy	5.0	6.6	9.4	12.0	7.9	4.4	GJ
Electric energy	0	0	0	0	0	0	J
Fuel costs	114.6	151.4	218.5	276.8	183.6	100.5	euro
Mass of produced H <sub>2</sub> O	125.1	165.3	238.5	302.1	200.3	109.7	kg
Mass of produced CO <sub>2</sub>	363.5	480.4	693.1	878.1	582.3	318.7	kg
Mass of produced O <sub>2</sub>	0	0	0	0	0	0	kg
Mass of produced SO <sub>2</sub>	9.5	12.5	18.1	22.9	15.2	8.3	kg
Mass of produced N <sub>2</sub>	0	0	0	0	0	0	kg
Mass of produced NO <sub>x</sub>	0	0	0	0	0	0	kg
Mass of produced CO	0	0	0	0	0	0	kg
Mass of produced C <sub>x</sub> H <sub>y</sub>	0	0	0	0	0	0	kg

Examining the existing system of the oil furnace for two different days with low and high occupancy, during the 6 May and the 4 August respectively, the following figures are extracted. Figures 5.3, 5.4 and 5.5 represent the temperature of the storage tank, the working hours of the furnace and the temperature that reaches the rooms for the 4 August (where the hotel has 100 % occupancy), while figures 5.6, 5.7 and 5.8 represent the temperature of the storage tank, the working hours of the furnace and the temperature that reaches the rooms for the 6 of May (where the hotel has 28.3 % occupancy).

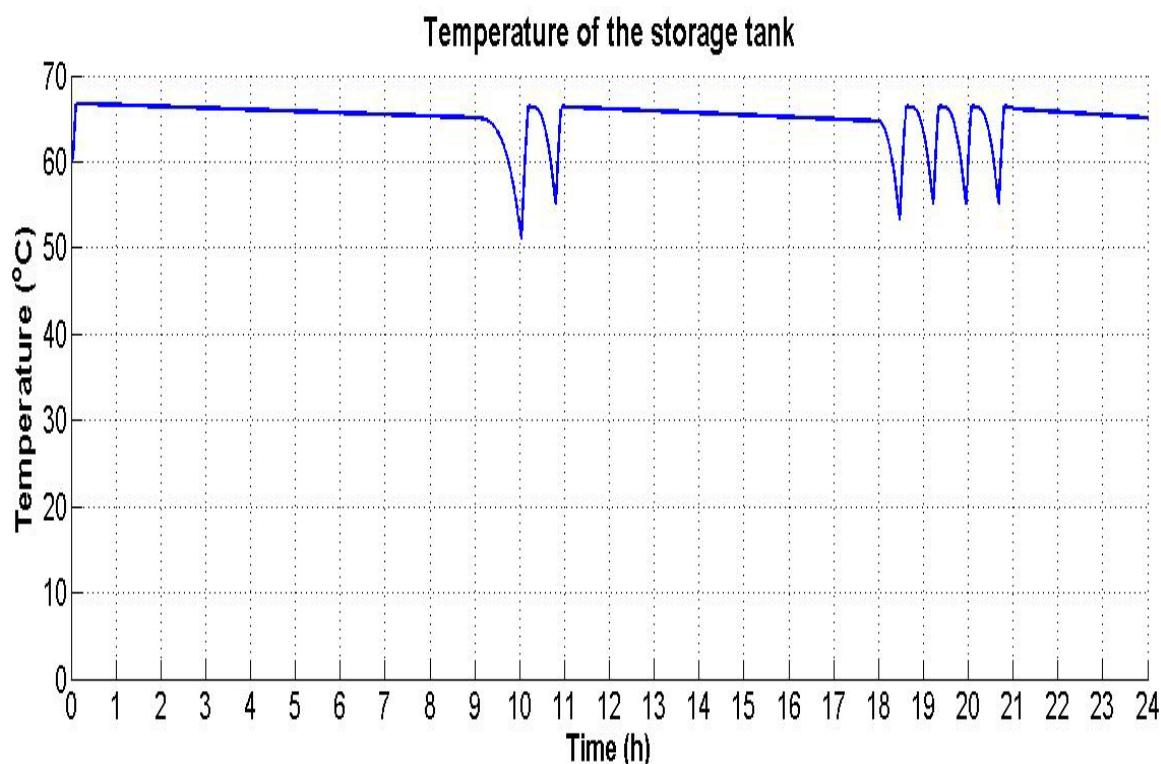

Fig.5.3: Temperature of the storage tank for the existing system of oil furnace for the 4 August

In the figure above it is observed that, due to the reduced losses in the tank, the temperature in the storage tank is not significantly reduced during the night, from 00:00 until

09:00. At 09:00, due to the increased demand in hot water, cold water enters the storage tank and the overall temperature starts to fall. When the temperature is reaching a critical level, then, as it is shown in Figure 5.4, the oil furnace starts to work, in order to keep the temperature of the storage tank always above 50 °C. At 11:00 when the demand of hot water stops (according to the peak hours of consumptions which was filled by the owner of the hotel) the storage tank restores its initial high temperature, and the oil furnace is not working. At 18:00 and until 21:00, more hot water is needed by the residents of the hotel. That is why cold water is inserted in the storage tank and reduces its initial temperature. One more time, the oil furnace starts to work, trying to keep the temperature of the storage tank above 50 °C. At 21:00 the demand of hot water stops, and the oil furnace stops working, while the storage tank restores its initial high temperature.

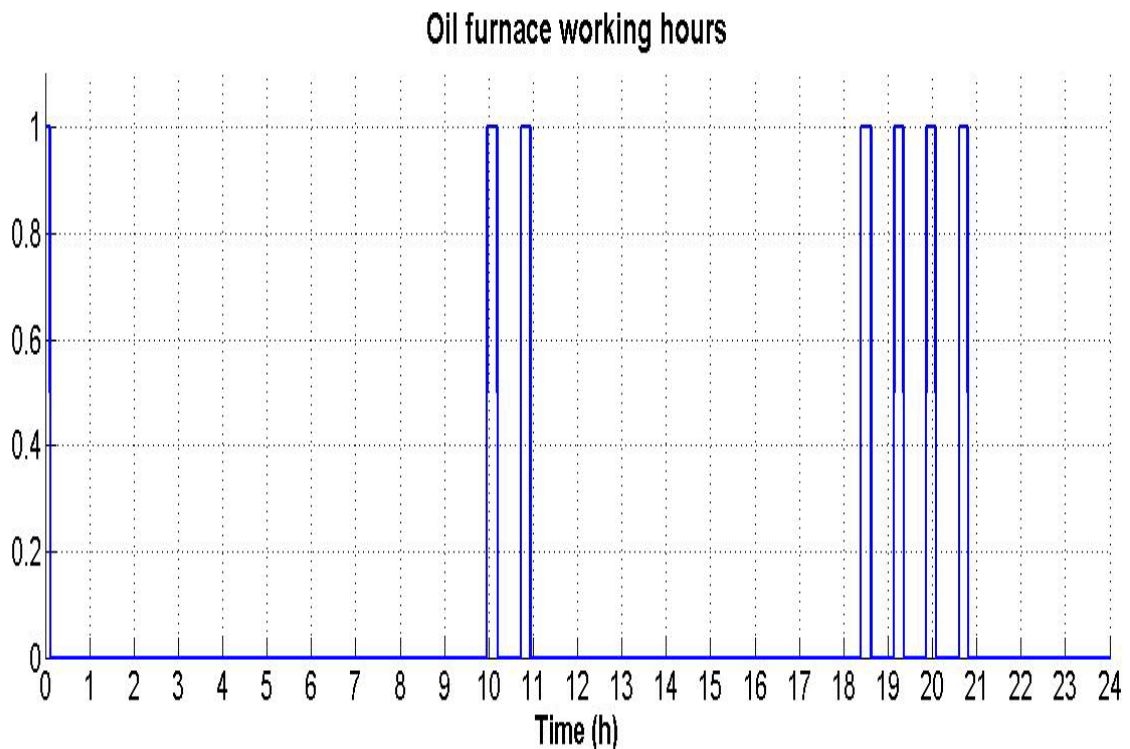

Fig.5.4: Working hours for the existing system of oil furnace for the 4 August

Figure 5.5 shows the temperature that finally reaches the rooms. It is worth noting that during the peak hours of consumption (09:00 - 11:00 and 18:00 - 21:00), although the hotel has 100 % occupancy and 1800 lt of hot water per day are needed, the temperature that reaches the room during these peak hours is stable at 50 °C, as it is requested by the T.O.T.E.E. During the other hours of the day, where there is no consumption of hot water, the water temperature is smaller than 50 °C, as the water stays inside the pipes, which have certain losses.

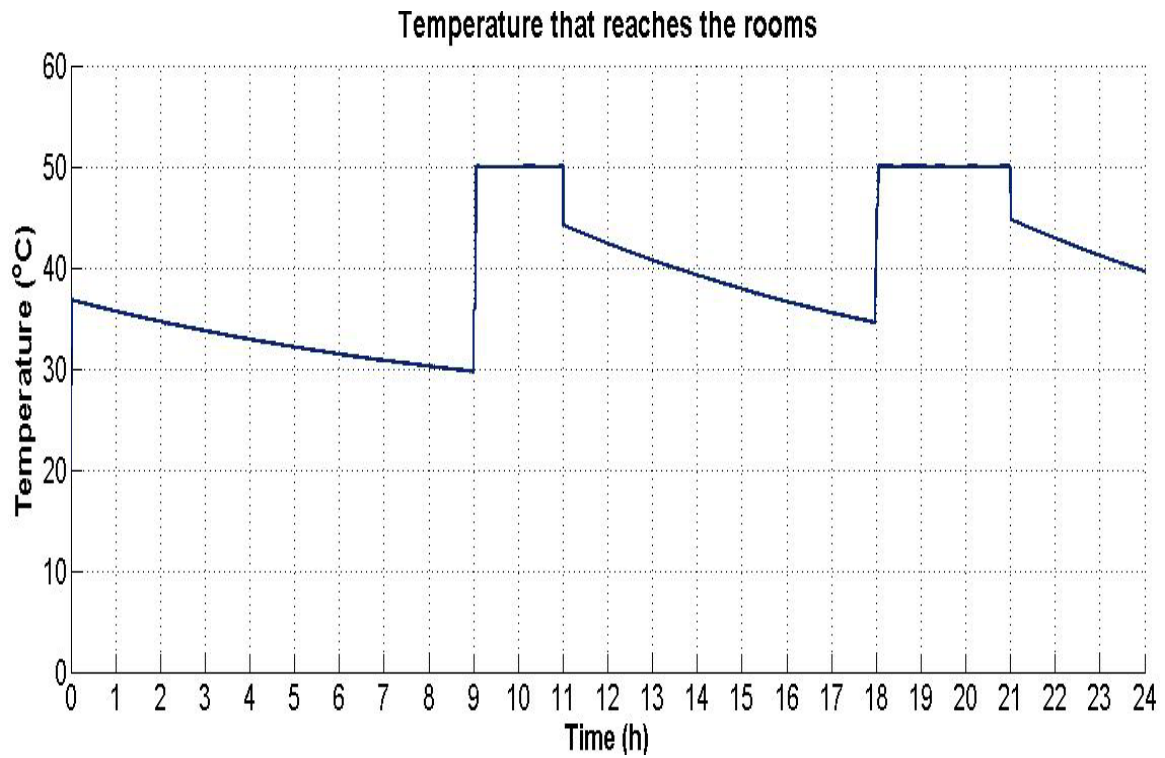

Fig.5.5: Temperature of the hot water that reaches the rooms for the 4 August

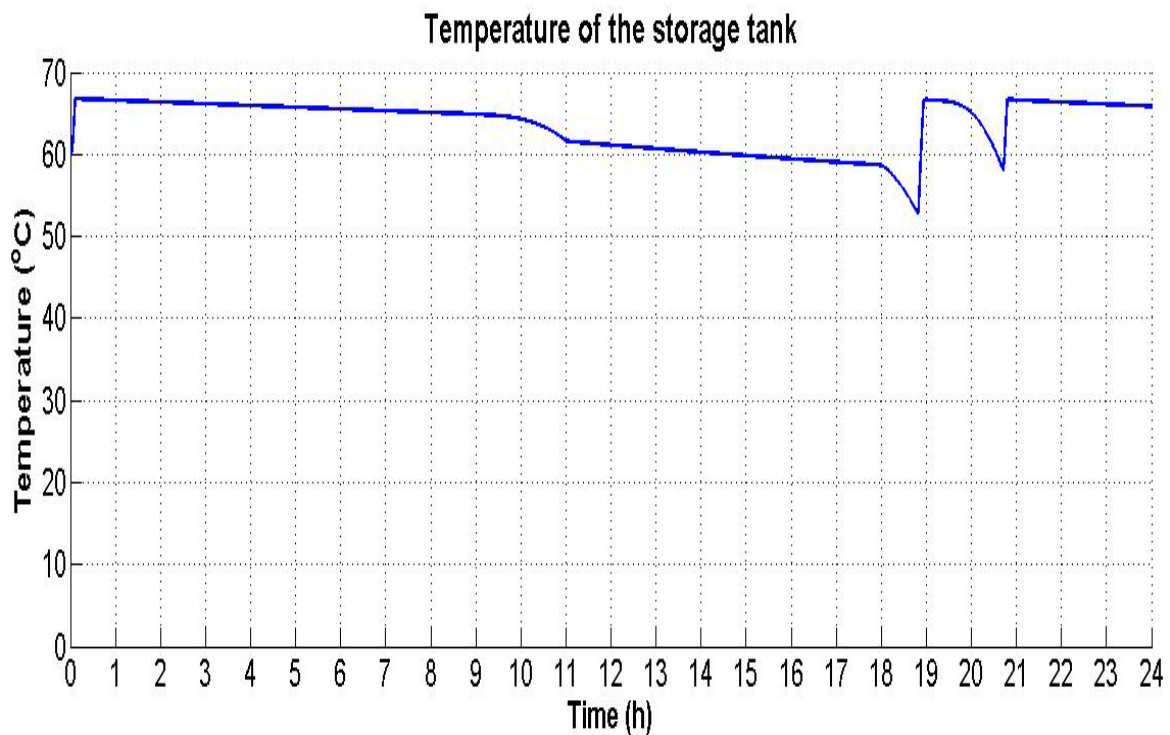

Fig.5.6: Temperature of the storage tank for the existing system of oil furnace for the 6 May

Figure 5.6 shows the temperature of the storage tank for the 6<sup>th</sup> May. The demand for hot water in May is smaller than August, since the occupancy in May is smaller. During the peak

hours of consumption, from 09:00 - 11:00, the temperature of the storage tank is reduced, but due to the fact that it does not reach the critical temperature, as is it shown in Figure 5.7, the oil furnace does not start to work. On the contrary, during the afternoon peak hours of consumption, from 18:00 - 21:00, due to the fact that the temperature of the storage tank reaches the critical temperature, the oil furnace starts to work.

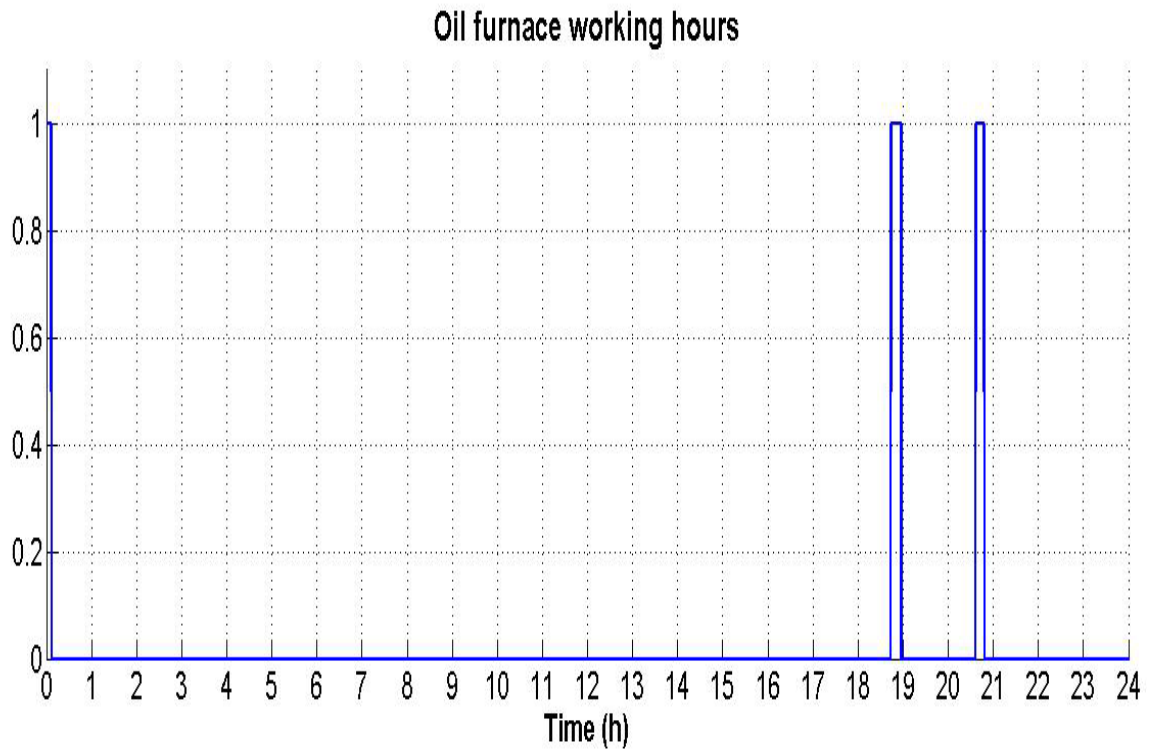

Fig.5.7: Working hours for the existing system of oil furnace for the 6 May

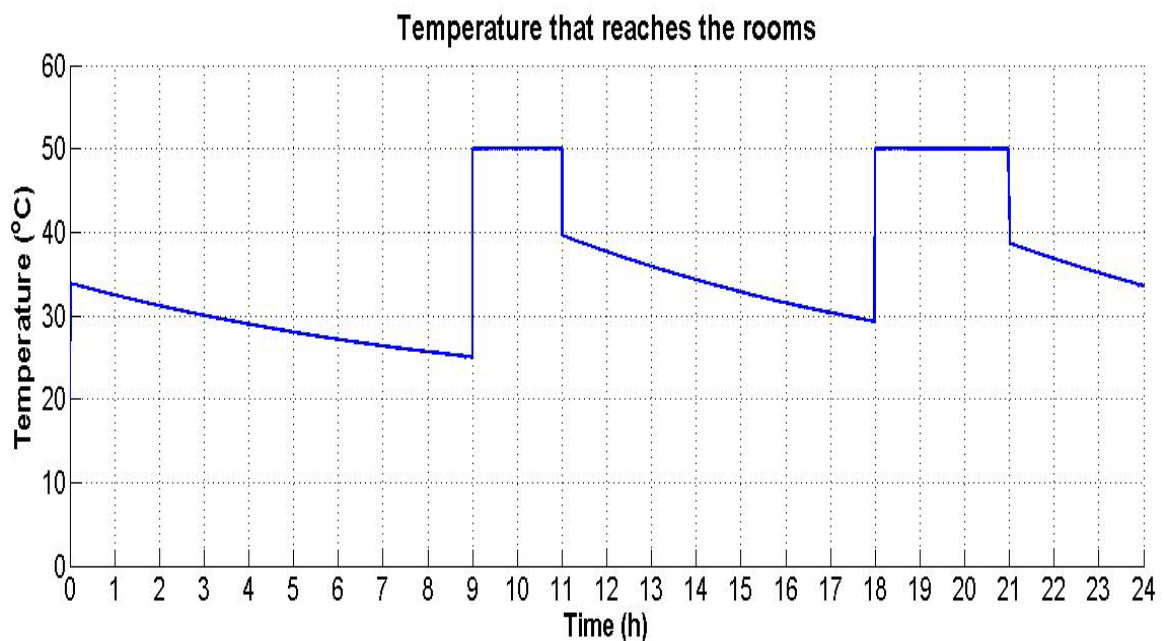

Fig.5.8: Temperature that finally reaches the rooms for the existing system of oil furnace for the 6 May

Figure 5.8 presents the temperature that finally reaches the rooms. Although in May the occupancy of the hotel is less than in August, the temperature during the peak hours of consumption is steady at 50 °C. During the other hours of the day, where there is no consumption, the temperature of the water is less than 50 °C, due to the fact that it stays inside the pipes, which have losses.

For these two days, the ecology block gives the following values, which are inserted in Table 26 below.

Table 26: Comparison of the ecology block between 6 May and 4 August for the existing system of the oil furnace

Parameter	6 May	4 August	Unit
Mass of fuel	3.2	8.7	kg
Thermal energy	136	363	GJ
Fuel costs	3.1	8.4	euro
Mass of produced H <sub>2</sub> O	3.4	9.1	kg
Mass of produced CO <sub>2</sub>	9.8	26.6	kg
Mass of produced SO <sub>2</sub>	0.3	0.7	kg

From the comparison of these two days is observed that during May the hotel has less operational costs per day, which is absolutely reasonable, since in May the occupancy is lower than in August.

## 5.2 Simulation results of the oil burner with the flat plate collectors

As it has already been reported in subchapter 4.4, the total surface of the flat plate collectors needed in order to achieve of at least a 60 % coverage ratio, is 22 m<sup>2</sup>. The remaining coverage ratio will be provided by the oil furnace, in order to have the fully coverage of the needs in hot water of use for the hotel.

By running the simulation model with this surface of 22 m<sup>2</sup> and the oil burner, the following tables (Table 27 and Table 28) were extracted, which concern the total operation of the hotel and the monthly values respectively.

Table 27: Total operational cost of the oil furnace and the 22 m<sup>2</sup> of flat plate collectors

Parameter	Value	Unit
Mass of fuel	408.3	kg
Thermal energy	17.1	GJ
Electric energy	0	J
Fuel costs	393.9	euro
Mass of produced H <sub>2</sub> O	429.8	kg
Mass of produced CO <sub>2</sub>	1249.3	kg
Mass of produced O <sub>2</sub>	0	kg
Mass of produced SO <sub>2</sub>	32.6	kg
Mass of produced N <sub>2</sub>	0	kg
Mass of produced NO <sub>x</sub>	0	kg
Mass of produced CO	0	kg
Mass of produced C <sub>x</sub> H <sub>y</sub>	0	kg

Table 28: Oil furnace and 22 m<sup>2</sup> of flat plate collectors consumption, for each month of operation separately

Parameter	May	June	July	August	September	October	Unit
Mass of fuel	17.3	55.9	74.6	132.7	87.3	40.4	kg
Thermal energy	0.7	2.3	3.1	5.5	3.6	1.7	GJ
Electric energy	0	0	0	0	0	0	J
Fuel costs	16.7	53.9	72.0	128.0	84.2	39.0	euro
Mass of produced H <sub>2</sub> O	18.2	58.8	78.6	139.7	91.9	42.6	kg
Mass of produced CO <sub>2</sub>	53.0	171.0	228.4	406.0	267.2	123.7	kg
Mass of produced O <sub>2</sub>	0	0	0	0	0	0	kg
Mass of produced SO <sub>2</sub>	1.4	4.5	6.0	10.6	7.0	3.2	kg
Mass of produced N <sub>2</sub>	0	0	0	0	0	0	kg
Mass of produced NO <sub>x</sub>	0	0	0	0	0	0	kg
Mass of produced CO	0	0	0	0	0	0	kg
Mass of produced C <sub>x</sub> H <sub>y</sub>	0	0	0	0	0	0	kg

By examining the system of the oil burner and the 22 m<sup>2</sup> of flat plate collectors for the same month of August (with 100 % occupancy), and for two different days, one with high solar radiation (3 August), and one with low solar radiation (4 August), the following figures were extracted. Figures 5.9, 5.10, 5.11 and 5.12 describe the solar radiation, the temperature of the storage tank, the oil furnace working hours and the temperature that finally reaches the

rooms, for the 3 August with the high direct solar radiation, while figures 5.13, 5.14, 5.15 and 5.16 describe the same values but for the 4 August, with the low direct solar radiation.

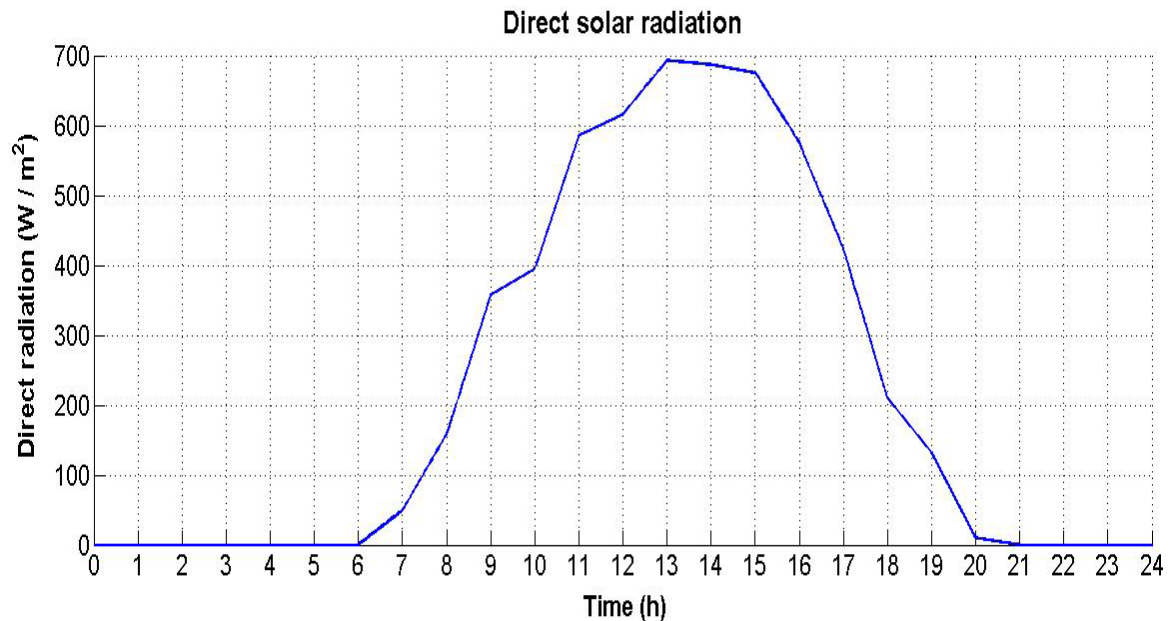

Fig.5.9: Direct solar radiation for the oil furnace and the flat plate collectors, for the 3 August

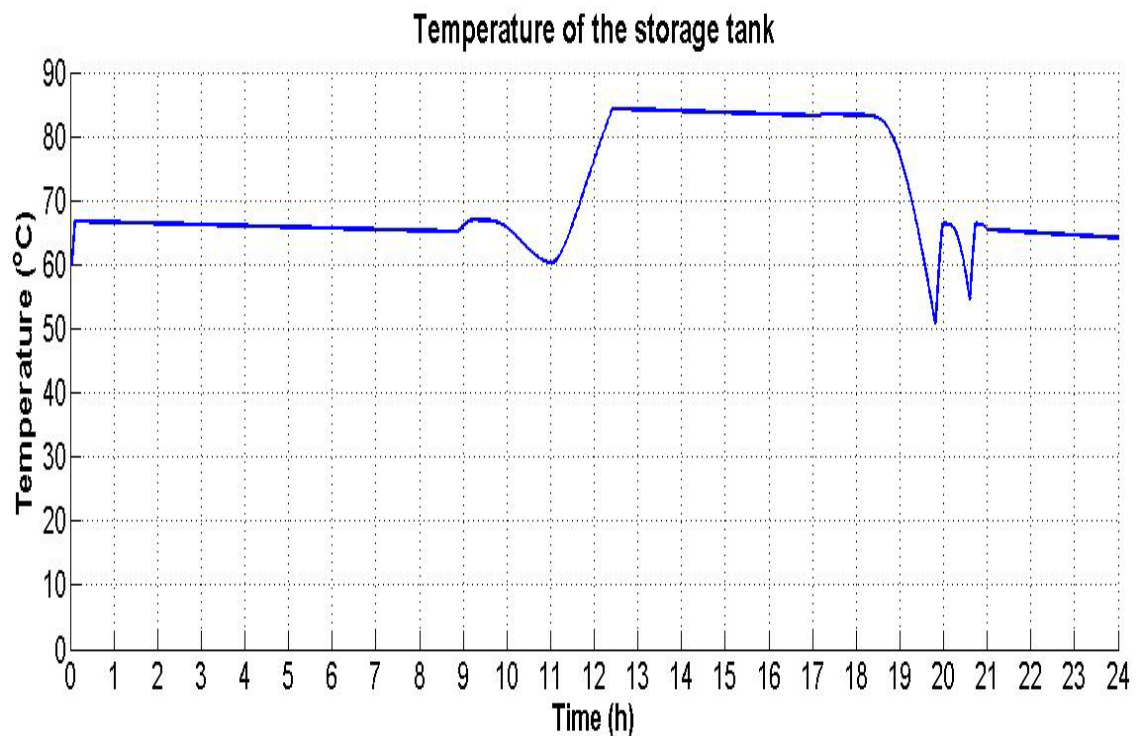

Fig.5.10: Temperature of the storage tank for the oil furnace and the flat plate collectors, for the 3 August

Figure 5.9 shows the direct solar radiation for the 3 August, which ranges from 0 W / m<sup>2</sup> up to 700 W / m<sup>2</sup>, during the solar noon. Figure 5.10 shows the temperature of the storage tank of the hybrid system of the oil furnace and the 22 m<sup>2</sup> of flat plate collectors, for the 3 August. During the morning hours of peak consumption (09:00 - 11:00), due to the fact that the direct solar radiation ranges from around 360 W / m<sup>2</sup> up to 590 W / m<sup>2</sup>, the temperature of



the storage tank does not reach a critical level, and that is why, in Figure 5.11, the oil furnace is not working. During the afternoon peak hours of consumption (18:00 - 21:00), due to the fact that the direct solar radiation is low (lower than  $100 \text{ W / m}^2$ ), the oil furnace starts to work, in order to heat the water.

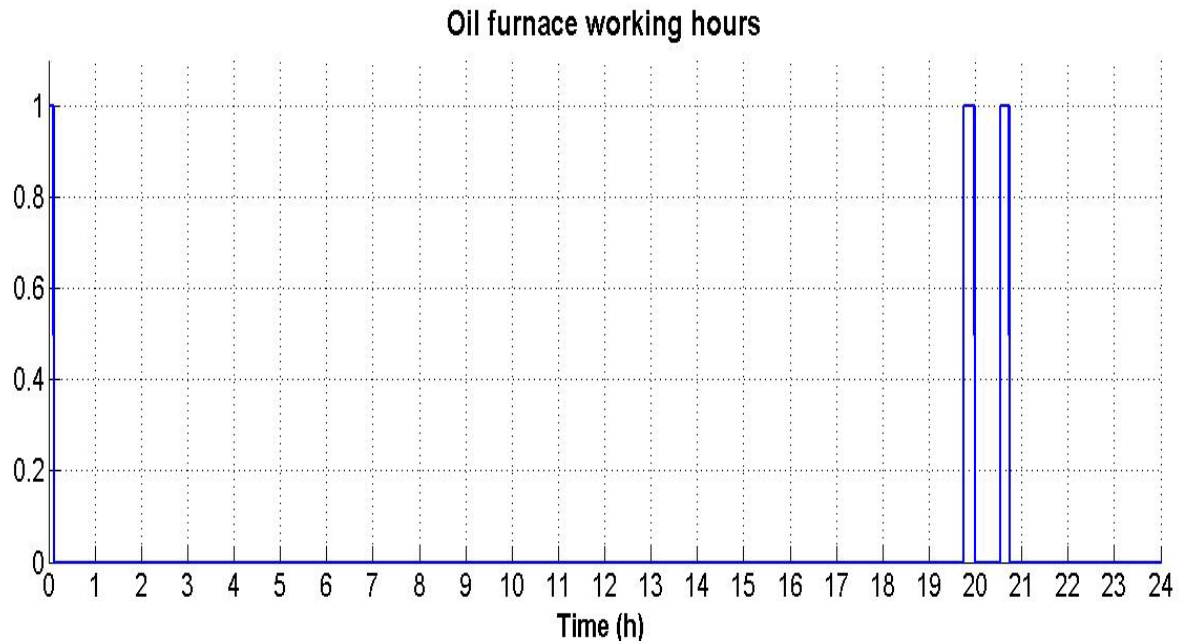

Fig.5.11: Oil furnace working hours for the hybrid system, for the 3 August

Figure 5.12 displays the temperature that finally reaches the rooms for the 3 August. During the peak hours of consumption (09:00 - 11:00 and 18:00 - 21:00) the temperature of the hot water is steady at  $50 \text{ }^\circ\text{C}$ . During the other hours of the day, where there is no consumption, the temperature of the water is less than  $50 \text{ }^\circ\text{C}$ , due to the fact that it stays inside the pipes, which have losses.

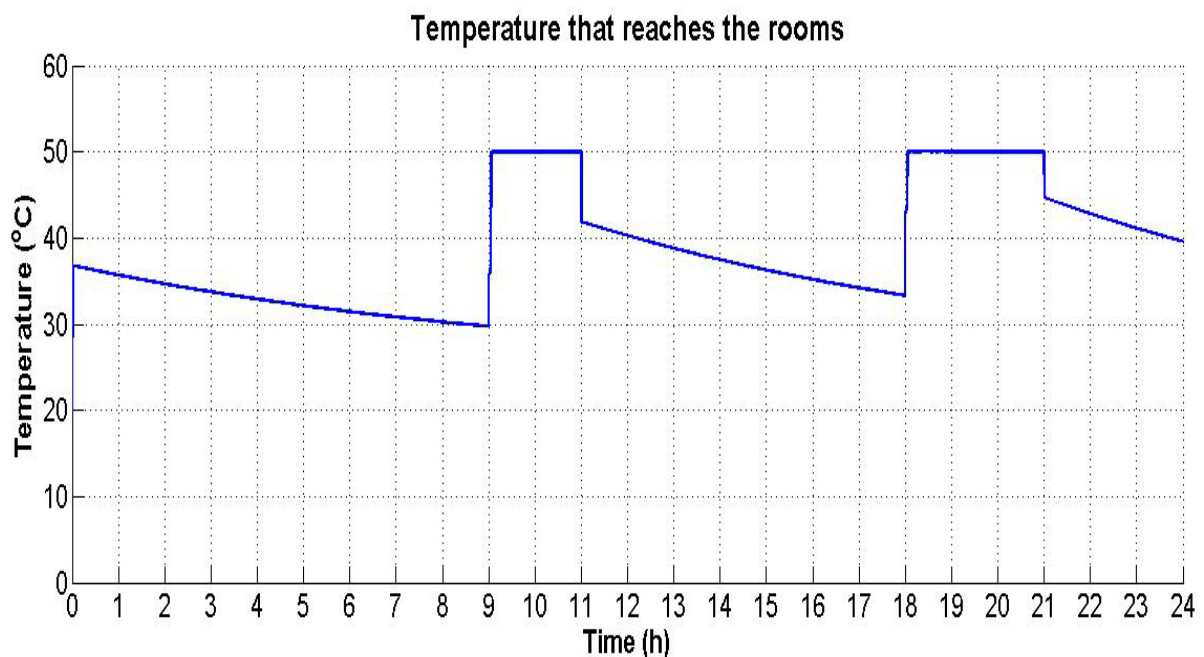

Fig.5.12: Temperature that finally reaches the rooms for the hybrid system, for the 3 August

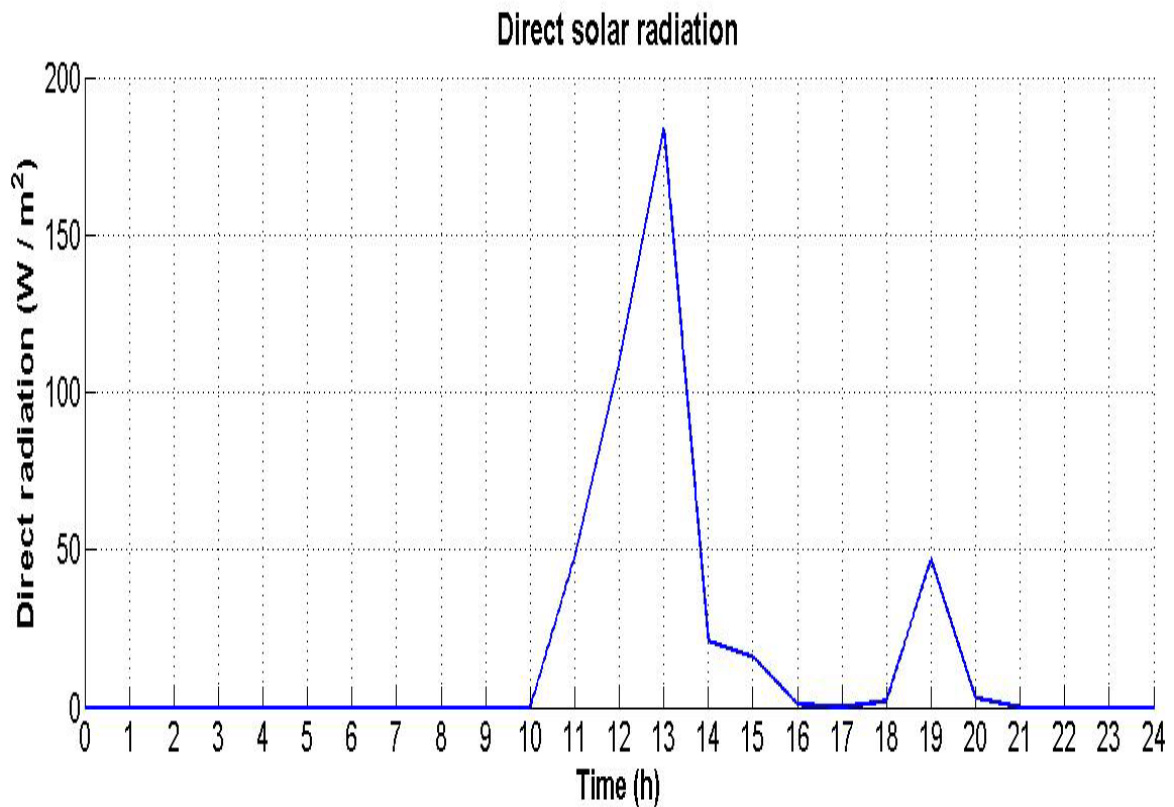

Fig.5.13: Direct solar radiation for the oil furnace and the flat plate collectors, for the 4 August

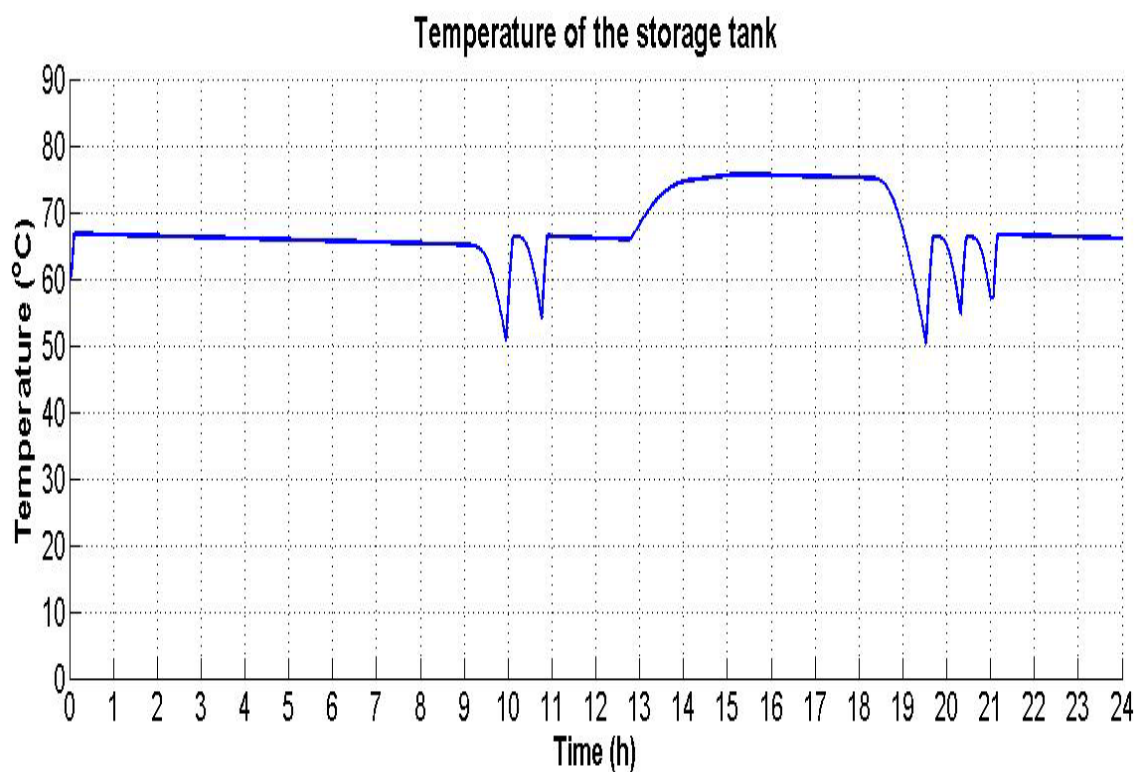

Fig.5.14: Temperature of the storage tank for the oil furnace and the flat plate collectors, for the 4 August

Figure 5.13 shows the direct solar radiation for the 4 August, which ranges from 0 W / m<sup>2</sup> up to 180 W / m<sup>2</sup> during the solar noon. In this case, and due to the fact that the direct solar

radiation is too low, during the morning and the afternoon peak hours of consumption, the solar radiation is not enough to heat the water of the storage tank, and that is why the temperature of the storage tank reaches the critical temperature of 50 °C. At these points, and according to Figure 5.15, the oil furnace starts to work, in order to raise the temperature of the water which is inside the storage tank.

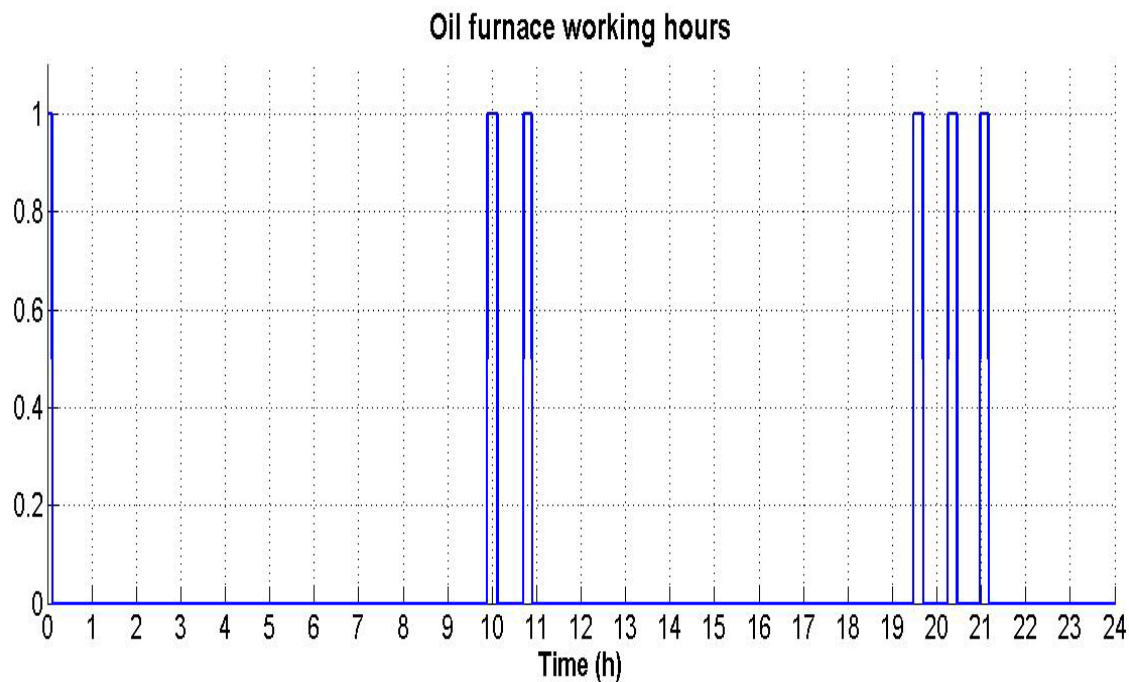

Fig.5.15: Oil furnace working hours for the hybrid system, for the 4 August

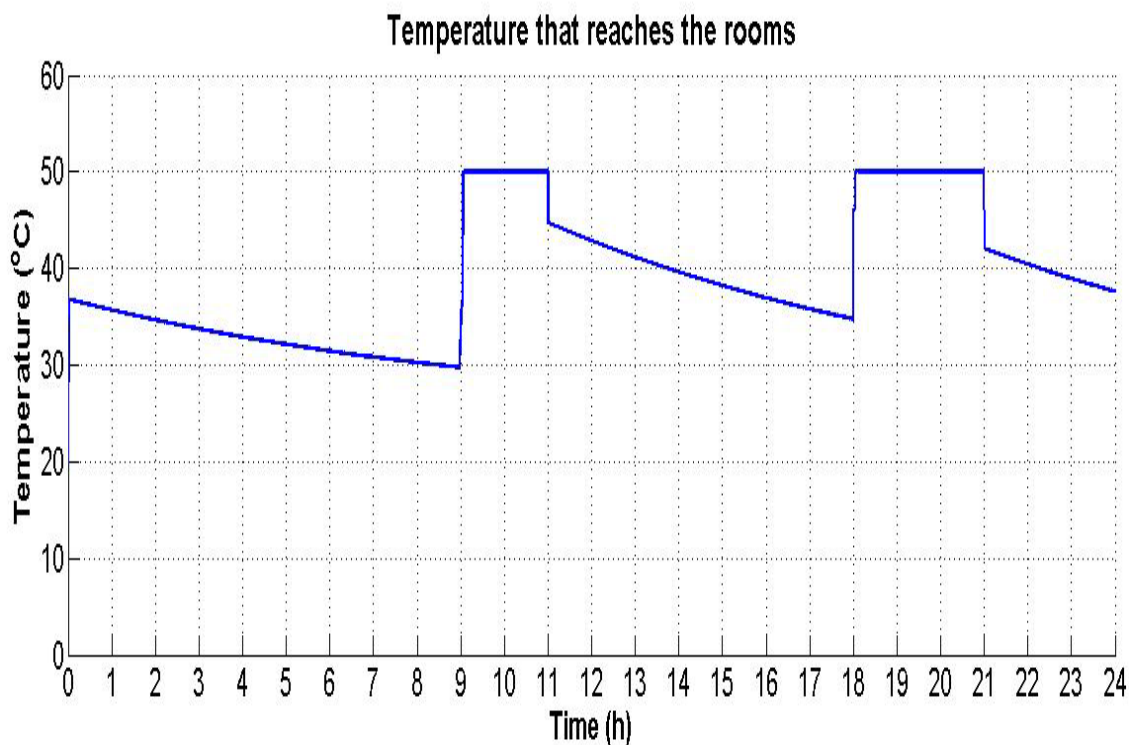

Fig.5.16: Temperature that finally reaches the rooms for the hybrid system, for the 4 August

Figure 5.16 shows the temperature of the hot water that finally reaches the rooms, for the hybrid system of the oil furnace and the 22 m<sup>2</sup> of flat plate collectors and for the 4 August. Although there is no high direct solar radiation, the oil furnace, by working more hours, manages to keep the temperature that reaches the rooms during the peak hours of consumption stable, at 50 °C.

The comparison of the ecology block, between these two days of August, with high and low direct solar radiation provides the following table (Table 29).

Table 29: Comparison of the ecology block between the 3 and the 4 of August for the hybrid system of the oil furnace and the flat plate collectors

Parameter	3 August	4 August	Unit
Mass of fuel	3.4	7.1	kg
Thermal energy	144	296	GJ
Fuel costs	3.3	6.8	euro
Mass of produced H <sub>2</sub> O	3.6	7.4	kg
Mass of produced CO <sub>2</sub>	10.4	21.6	kg
Mass of produced SO <sub>2</sub>	0.3	0.6	kg

Table 29 shows the crucial importance of the direct solar radiation on the hybrid system of the oil furnace and the flat plate collectors. With only one day difference, due to the fact that on 4 August there is no direct solar radiation, the oil furnace is forced to work more hours in order to keep the temperature that reaches the rooms stable at 50 °C. That way, it burns almost twice the amount of fuel, and results in double operational cost of the hotel during that day.

### 5.3 Simulation results for the biomass burner by adding the flat plate collectors

This scenario examines the case that the owner, along with the installation of the flat plate collectors, would like to replace the oil burner with another one of the same nominal power biomass burner, which burns wood pellets. In this case, and under the condition that the mass flow of the close cycle of the burner and the collector surface remained the same as the oil burner, then all that would change in the simulation model would be the block of the fuel and the ecology block.

Table 5.6 [42] describes the ultimate analysis, as well as the Gross Calorific Value (GCV) and the Net Calorific Value (NCV) of wood pellets. The ultimate analysis provides the necessary data of mass fraction of the solid wood pellets, which are shown in Table 30:

Table 30: Mass fraction of wood pellets

Name of Substance	
Carbon	0.335
Hydrogen	0.06
Sulfur	0.0
Nitrogen	0.0
Oxygen	0.3
Moisture	0.3
Ash	0.005

The Gross Calorific Value (GCV) of the solid wood pellets is 20.53 MJ / kg and the Net Calorific Value (NCV) is 19.17 MJ / kg.

The wood pellet price for the prefecture of Corfu varies from 240 €/ t up to 290 €/ t, depending on the quality of the wood. An average price is 265 €/ t, or 0.265 €/ kg of wood pellets.

Table 31 presents all the parameters of the fuel block, which concern the replacement of the oil burner with a biomass burner which burns wood pellets.

Table 31: Parameters of the fuel source block, which burns wood pellets

Block Parameters: Fuel source		
Parameter	Value	Unit
Type of fuel	solid	-
Temperature	20	°C
Stoichiometric air demand	1	Kg/kg
Pressure	1e <sup>5</sup>	Pa
Heat without/with condensation	1.917e <sup>7</sup> 2.053e <sup>7</sup>	J/kg
Condensation temperature	45	°C
Price of fuel per kg	0.265	euro
Mass fraction [H C O S N H <sub>2</sub> O]	0.06 0.335 0.3 0 0 0	-

In this case, Table 32 shows the consumption, the thermal energy, the cost and the production of different elements in case of the hybrid system of the biomass burner and flat plate collectors.

Table 32: Total operational cost of the hybrid system of the biomass burner and the flat plate collectors

Parameter	Value	Unit
Mass of fuel	886.4	kg
Thermal energy	17.1	GJ
Electric energy	0	J
Fuel costs	234.9	euro
Mass of produced H <sub>2</sub> O	478.7	kg
Mass of produced CO <sub>2</sub>	1089.8	kg
Mass of produced O <sub>2</sub>	0	kg
Mass of produced SO <sub>2</sub>	0	kg
Mass of produced N <sub>2</sub>	0	kg
Mass of produced NO <sub>x</sub>	0	kg
Mass of produced CO	0	kg
Mass of produced C <sub>x</sub> H <sub>y</sub>	0	kg

By running the simulation model for each month of operation of the hotel separately, Table 33 was created:

Table 33: Biomass furnace and flat plate collectors consumption, for each month of operation separately

Parameter	May	June	July	August	September	October	Unit
Mass of fuel	37.7	119.3	162.5	288.7	188.0	90.2	kg
Thermal energy	0.7	2.3	3.1	5.5	3.6	1.7	GJ
Electric energy	0	0	0	0	0	0	J
Fuel costs	10.0	31.6	43.1	76.5	49.8	23.9	euro
Mass of produced H <sub>2</sub> O	20.4	64.4	87.8	155.9	101.5	48.7	kg
Mass of produced CO <sub>2</sub>	46.4	146.6	199.8	355.0	231.1	110.9	kg
Mass of produced O <sub>2</sub>	0	0	0	0	0	0	kg
Mass of produced SO <sub>2</sub>	0	0	0	0	0	0	kg
Mass of produced N <sub>2</sub>	0	0	0	0	0	0	kg
Mass of produced NO <sub>x</sub>	0	0	0	0	0	0	kg
Mass of produced CO	0	0	0	0	0	0	kg
Mass of produced C <sub>x</sub> H <sub>y</sub>	0	0	0	0	0	0	kg

By testing the hybrid system of the biomass furnace and the flat plate collectors for two different days of May (where the hotel has the lowest occupancy), and for high and low direct solar radiation, the following figures were extracted. Figures 5.17, 5.18, 5.19 and 5.20 concern the direct solar radiation, the storage tank temperature, the biomass furnace working hours and the temperature that reaches the rooms for the 1 May (low direct solar radiation), where Figures 5.21, 5.22, 5.23 and 5.24 concern the same values for the 6 May, with high direct solar radiation.

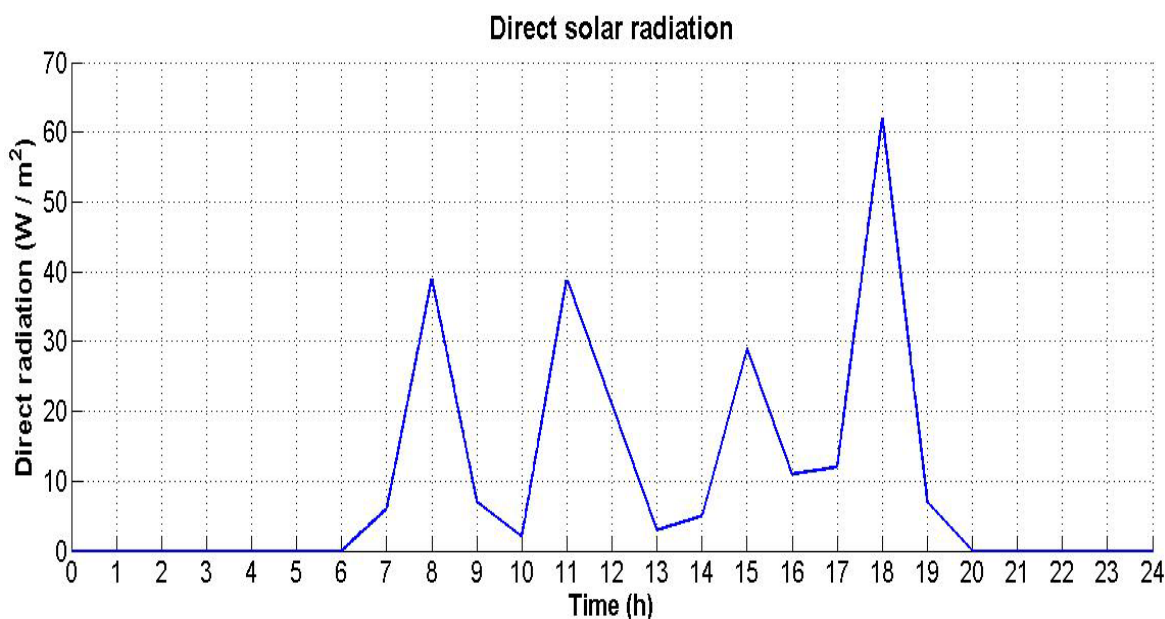

Fig.5.17: Direct solar radiation for the hybrid system of biomass furnace and flat plate collectors, for the 1 May

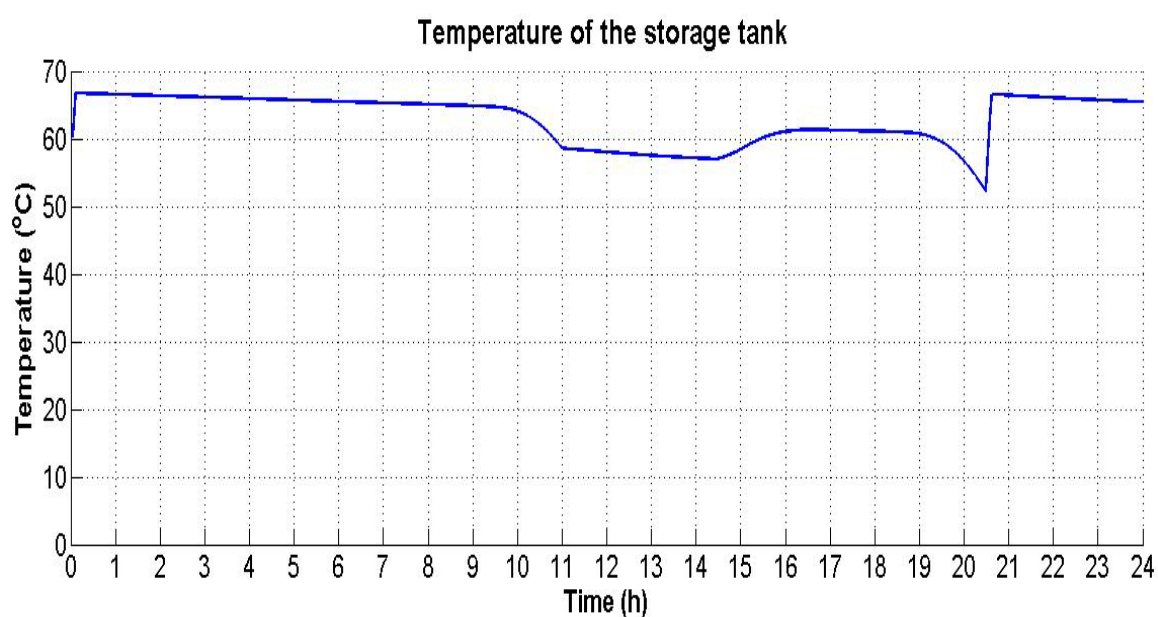

Fig.5.18: Temperature of the storage tank for the biomass furnace and the flat plate collectors, for the 1 May

Figure 5.17 presents the direct solar radiation, which varies from  $0 \text{ W / m}^2$  up to  $62 \text{ W / m}^2$ , for the 1 May. During the morning peak hours of consumption (09:00 - 11:00), the direct solar radiation ranges from  $8 \text{ W / m}^2$  up to  $39 \text{ W / m}^2$ , which is not enough to heat the water. Despite that, the biomass furnace in Figure 5.19 is not working, because the storage tank has high temperature from the previous day and because during the night hours (00:00 – 08:00) the storage tank has little losses. Another one factor that the biomass furnace is not working is the low occupancy, meaning that there is no high demand in hot water (according to Table 2, only 510 lt are needed for each day of May, when the storage tank has a capacity of 350 lt). Continuously, and during the hours of no consumption of hot water (11:00 - 18:00) the direct solar radiation continues to be low, and that is why the storage tank cannot return to its initial

high temperature. So, when the afternoon peak hours of consumption start (18:00 - 21:00), the temperature of the hot water inside the storage tank continues to fall, and around 20:30, is reaching the critical temperature of 50 °C. At this time, the biomass furnace starts to work, in order to heat the water of the storage tank.

**Biomass furnace working hours**

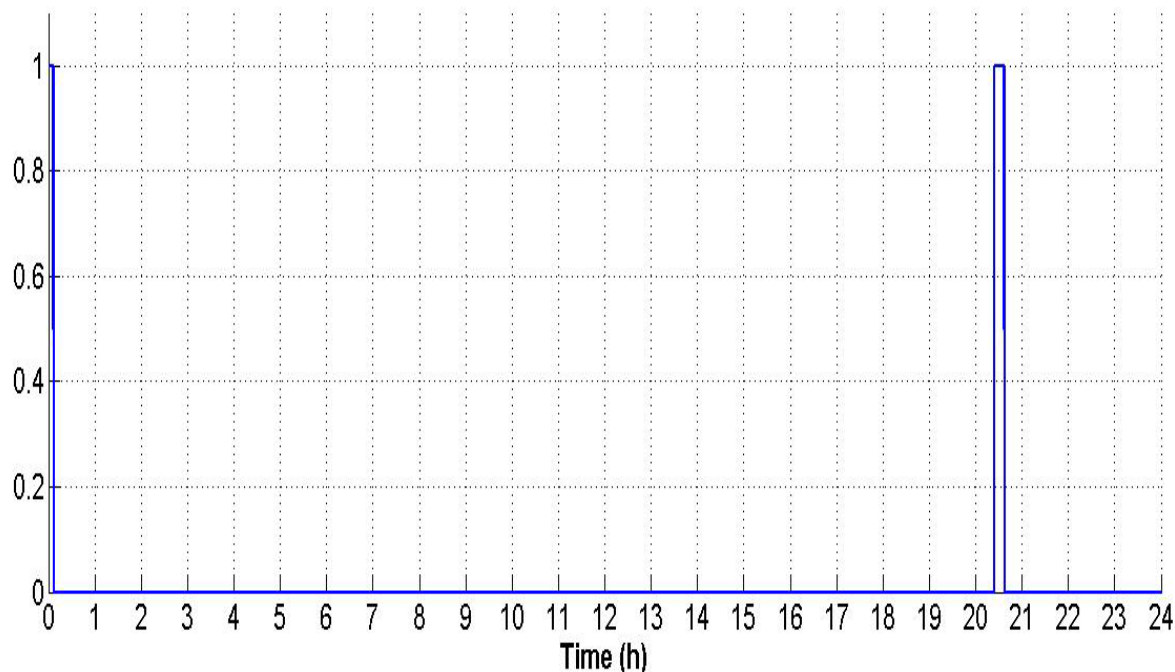

Fig.5.19: Biomass furnace working hours for the hybrid system, for the 1 May

**Temperature that reaches the rooms**

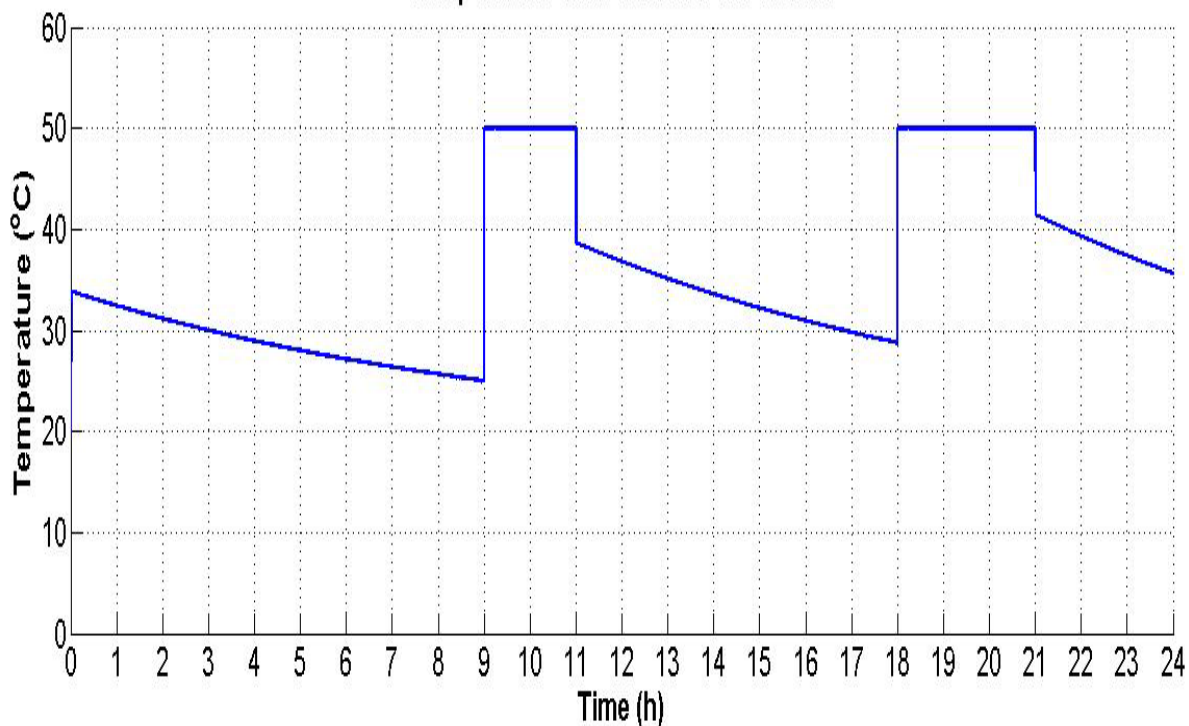

Fig.5.20: Temperature that reaches the rooms for the biomass furnace and the flat plate collectors, for the 1 May



Figure 5.20 illustrates the temperature that reaches the rooms in the hybrid system of the biomass furnace and the flat plate collectors on the 1 May. Although there is low direct solar radiation, and the biomass furnace is not working many hours, due to the low occupancy and the low demand in hot water, the temperature that reaches the rooms during the peak hours of consumption remains stable at 50 °C.

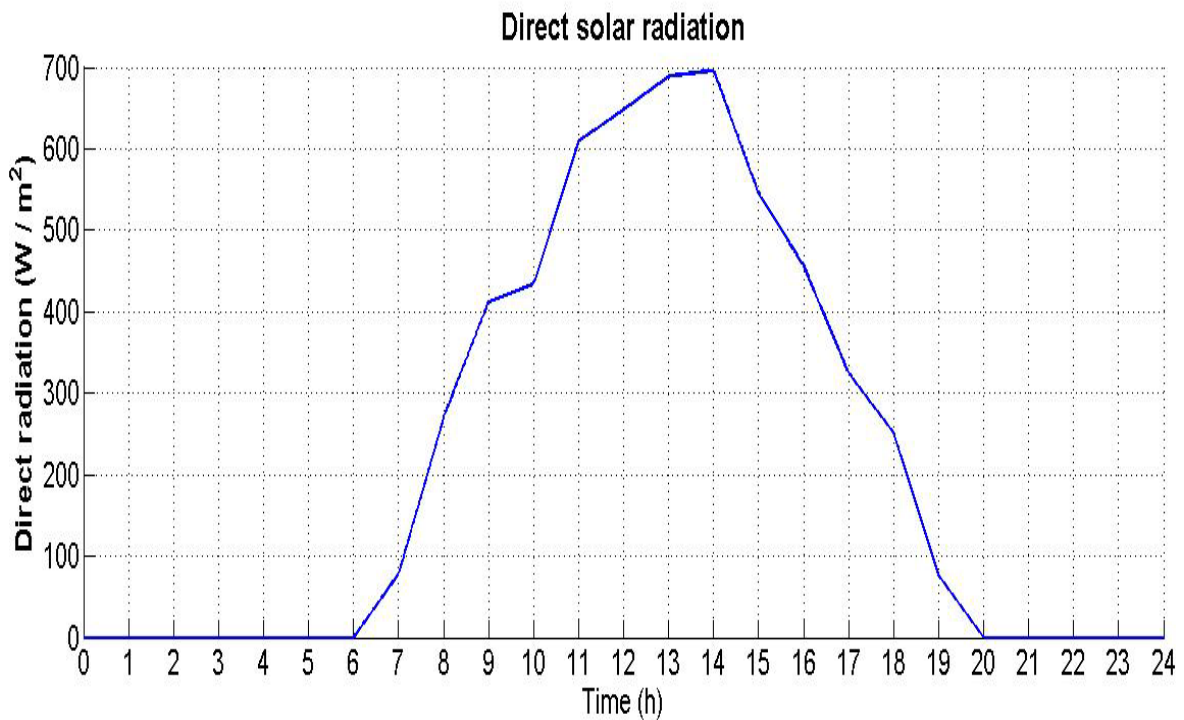

Fig.5.21: Direct solar radiation for the hybrid system of biomass furnace and flat plate collectors, for the 6 May

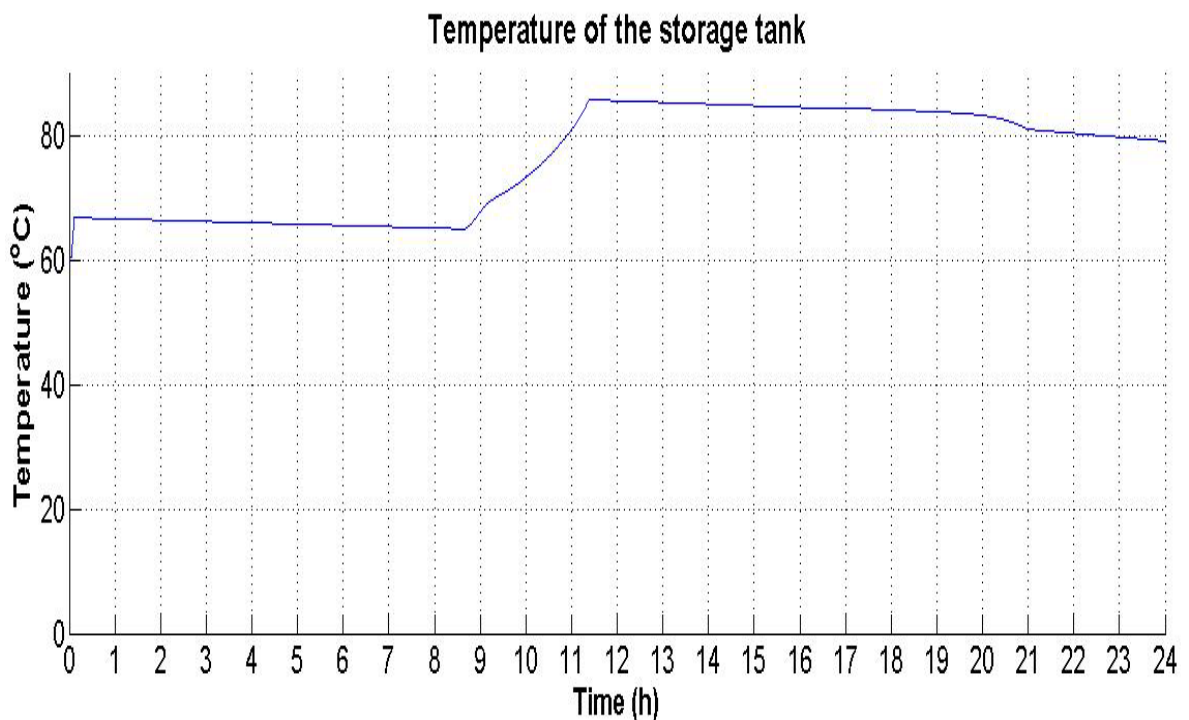

Fig.5.22: Temperature of the storage tank for the biomass furnace and the flat plate collectors, for the 6 May

Figure 5.21 shows the direct solar radiation, which varies from  $0 \text{ W / m}^2$  up to  $700 \text{ W / m}^2$ , for the hybrid system of the biomass furnace and the flat plate collectors, for the 6 May. During the morning peak consumption hours, due to the fact that the direct solar radiation is high ( $400 \text{ W / m}^2$  up to  $600 \text{ W / m}^2$ ), the temperature of the storage tank, at the peak hours of consumption, is high. The exact same thing happens also during the afternoon peak hours of consumption. Therefore the biomass furnace (Figure 5.23) is not working at all during the entire day, since all the demand for hot water is covered entirely by the flat plate collectors.

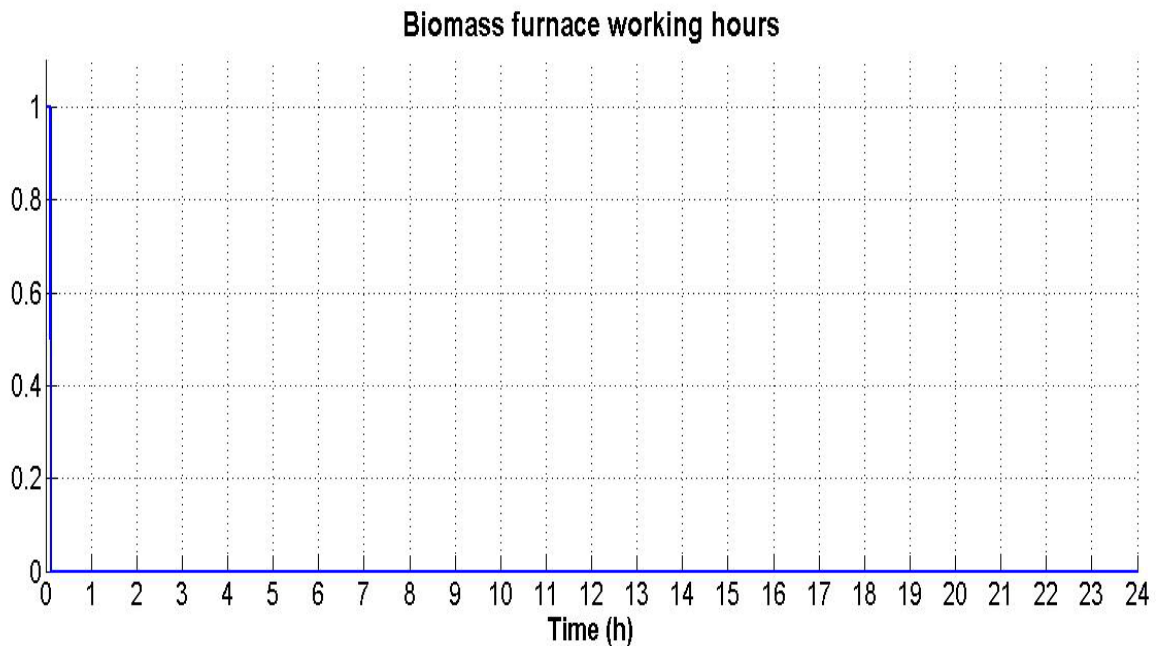

Fig.5.23: Biomass furnace working hours for the hybrid system, for the 6 May

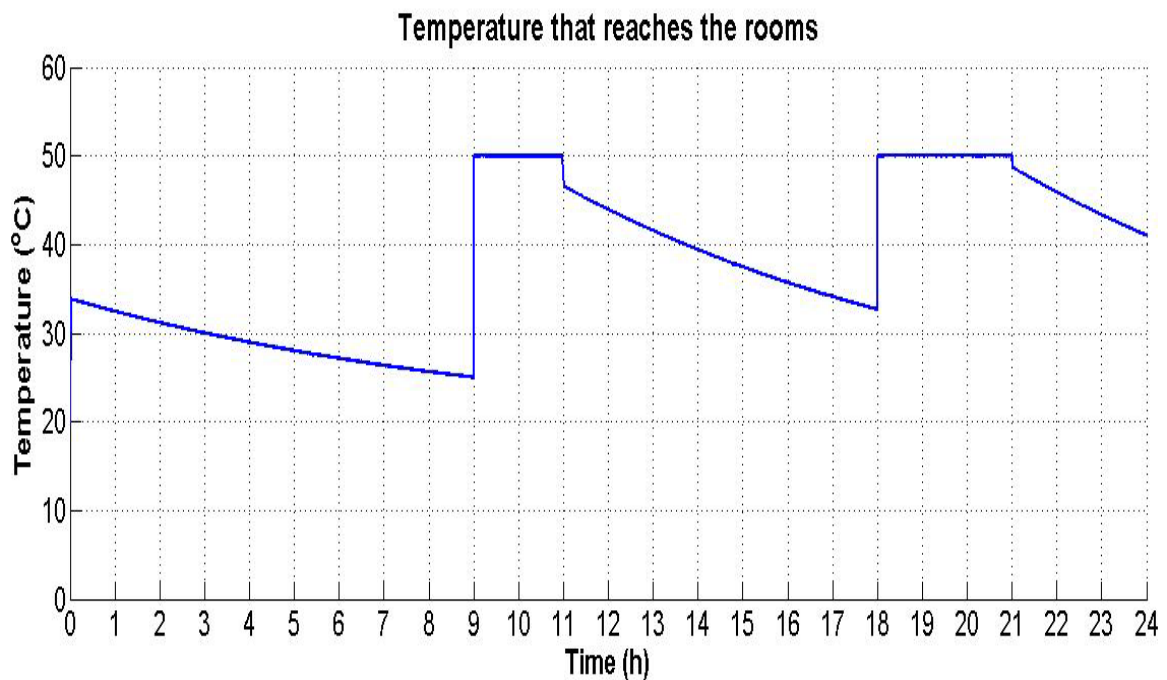

Fig.5.24: Temperature that reaches the rooms for the biomass furnace and the flat plate collectors, for the 6 May

Figure 5.24 shows the temperature that finally reaches the rooms for the hybrid system of the biomass furnace and the flat plate collectors. During the peak hours of consumption, the temperature remains stable at 50 °C.

By comparing the ecology block between these two days, the following table (Table 34) was extracted:

Table 34: Comparison of the ecology block between 1 and 6 May, for the hybrid system of the biomass furnace and the flat plate collectors

Parameter	3 August	4 August	Unit
Mass of fuel	4.5	1.5	kg
Thermal energy	87.6	29.6	GJ
Fuel costs	1.2	0.4	euro
Mass of produced H <sub>2</sub> O	2.4	0.8	kg
Mass of produced CO <sub>2</sub>	5.5	1.8	kg
Mass of produced SO <sub>2</sub>	0	0	kg

Table 34 shows the difference in the mass of produced CO<sub>2</sub> between these two days. Although the fuel cost between the two days is not considered important, the amount of carbon dioxide which is produced between these two days is considered too much.

## 5.4 Comparison between the different cases under examination

Due to the fact that the main purpose of the present master thesis is the reduction both of the fuel consumption and the emissions of CO<sub>2</sub>, with final aiming to the reduction of the operation cost for the hot water, it is deemed necessary to compare the above quantities for the three different cases.

Figures 5.25, 5.26 and 5.27 present the monthly values of the fuel consumption, for the existing system of the oil furnace, for the oil furnace and the flat plate collectors and for the flat plate collectors with the biomass furnace respectively. Figure 5.28 presents the fuel consumption in kg for the three different cases for the whole period of the hotel operation.

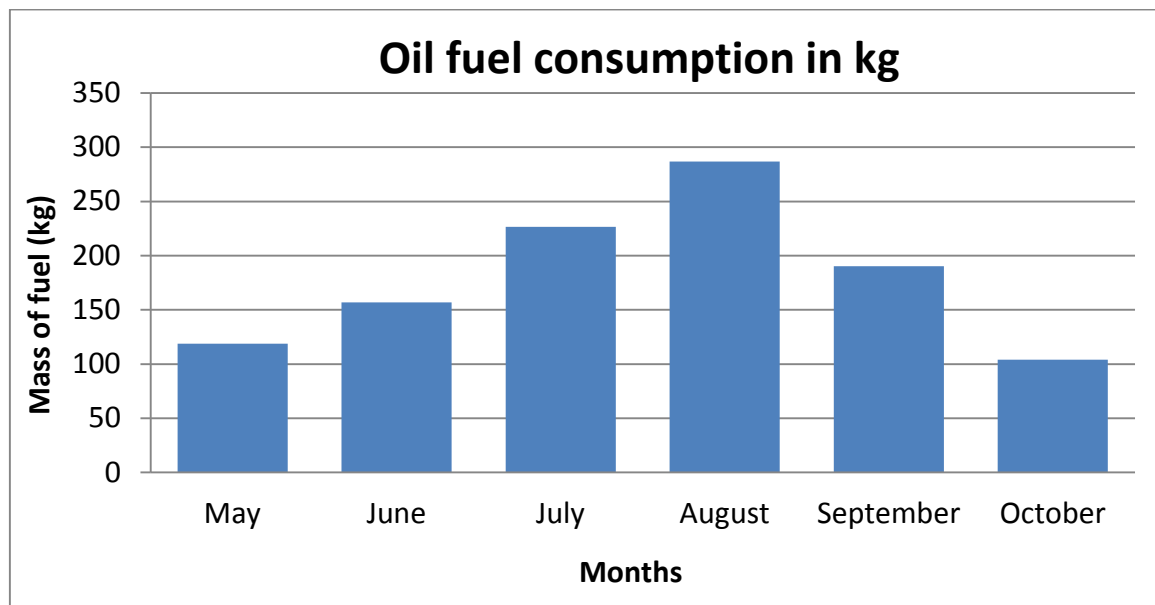

Fig.5.25: Monthly values of the fuel consumption for the existing system of the oil furnace

The oil fuel consumption for the existing system of the oil furnace depends on the occupancy of the hotel. That is why, in Figure 5.25, in August (100 % occupancy) the hotel has the maximum oil fuel consumption.

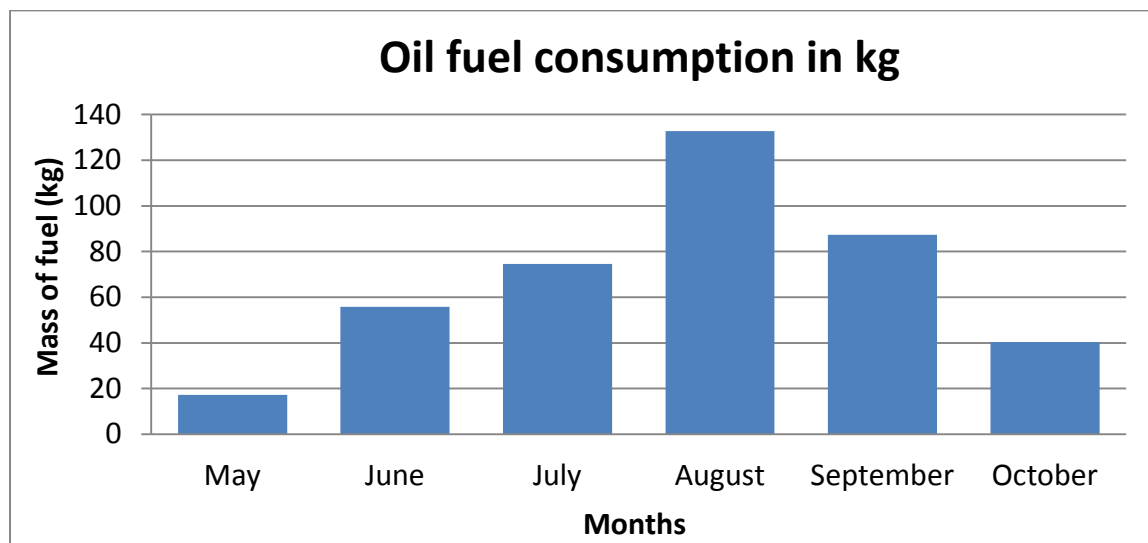

Fig.5.26: Monthly values of the fuel consumption for the oil furnace and the flat plate collectors

By adding the flat plate collectors to the existing system of the oil furnace, the oil fuel consumption is reduced, as it is observed in Figure 5.26. More specific, for the month of August, which is the month with the highest occupancy, from 289.6 kg of fuel, it is reduced to 132.7 kg of light oil fuel, which means that there is a reduction of 54.2 %.

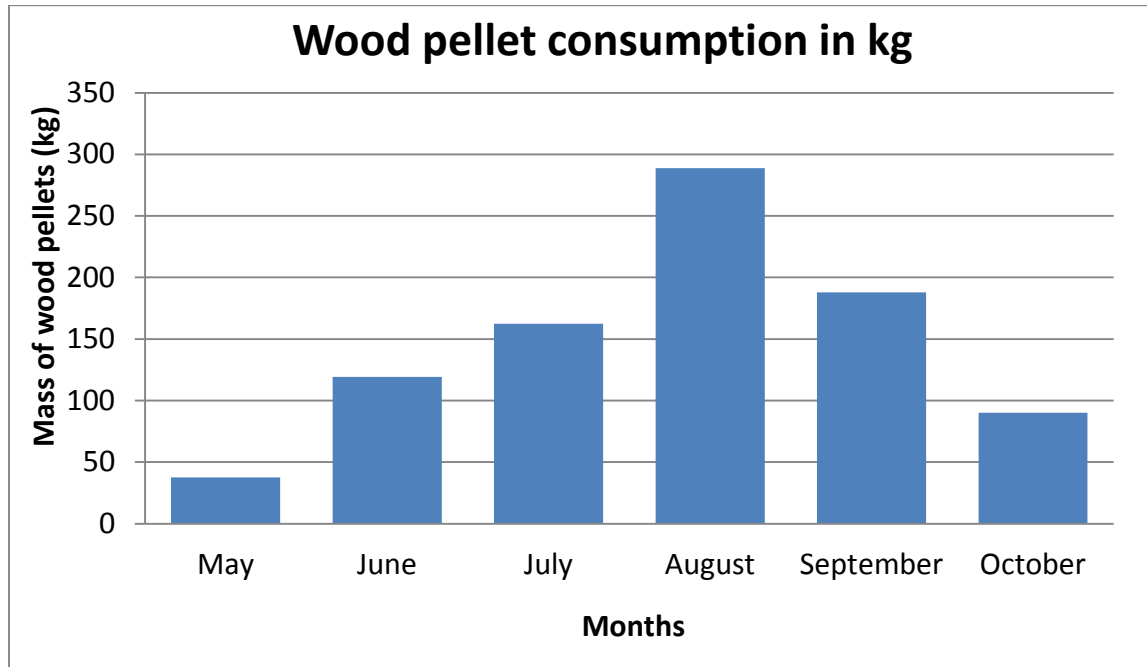

Fig.5.27: Monthly values of the fuel consumption for the biomass furnace and the flat plate collectors

By changing the oil furnace to a biomass furnace, and comparing the diagrams in Fig.5.26 and 5.27, is observed that the fuel consumption is increased. More specifically, for the month of August, with the highest occupancy, the oil furnace needs 132.7 kg of oil fuel, as Fig.5.26 shows, while the biomass furnace, for the same month, needs 288.7 kg of wood pellet according with Fig.5.27. This increase of the fuel consumption is due to the different values of the heat with and without condensation between the oil fuel (according to Table 23) and the values of the heat with and without condensation of the wood pellet (according to Table 31). Taking the average value of the heat condensation of the oil fuel ( $4.298e^7$  J / kg) and the average value of the heat condensation of the wood pellets ( $1.985e^7$  J / kg), it is observed that there is a reduction between these two average values by 53.8 %. This means that there is needed almost twice amount of wood pellets in kg in order to produce the same heat energy to heat the water of use. This also justifies why the fuel consumption results of the diagram in Fig.5.27 are doubled, in comparison to the diagram of Fig.5.26, for each month of the hotel operation.

Figure 5.28 below shows the reduction of the fuel consumption between the existing system of the oil furnace (1083.5 kg) and the second scenario of adding to the existing system the flat plate collectors (408.26 kg). This corresponds to a reduction in the fuel consumption equal to 62.3 %. On the contrary, on the third scenario, there is a shift by 100 % towards Renewable Energy Sources. That leads to a 100 % reduction of the conventional oil fuel, since the oil furnace is replaced by the wood pellet furnace.

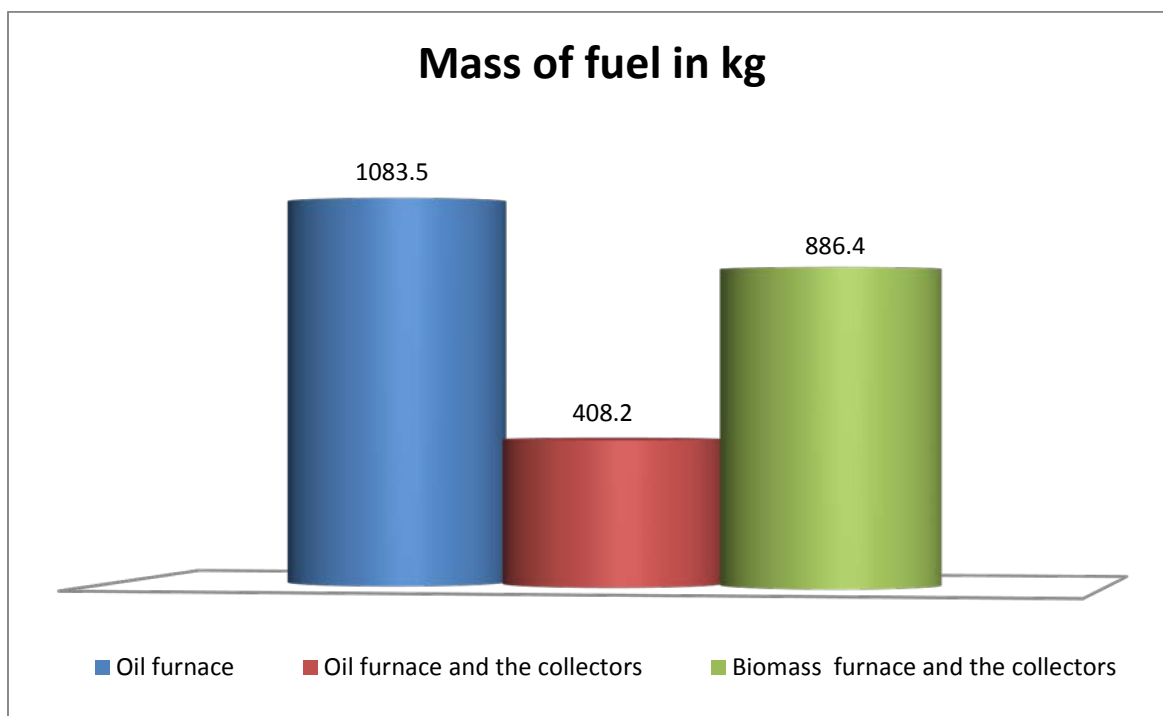

Fig.5.28: Fuel consumption for the three different cases for the whole period of operation of the hotel

Continuously, Figures 5.29, 5.30 and 5.31 present the monthly values of the CO<sub>2</sub> production for the three cases. More specifically, Figure 5.29 shows the monthly values of the CO<sub>2</sub> production for the existing system of the oil furnace, Figure 5.30 presents the monthly values of the CO<sub>2</sub> production for the oil furnace and the flat plate collectors and Figure 5.31 displays the monthly values of the CO<sub>2</sub> production for the biomass furnace and the flat plate collectors. Figure 5.32 presents the CO<sub>2</sub> production for the three different cases for the whole period of hotel operation.

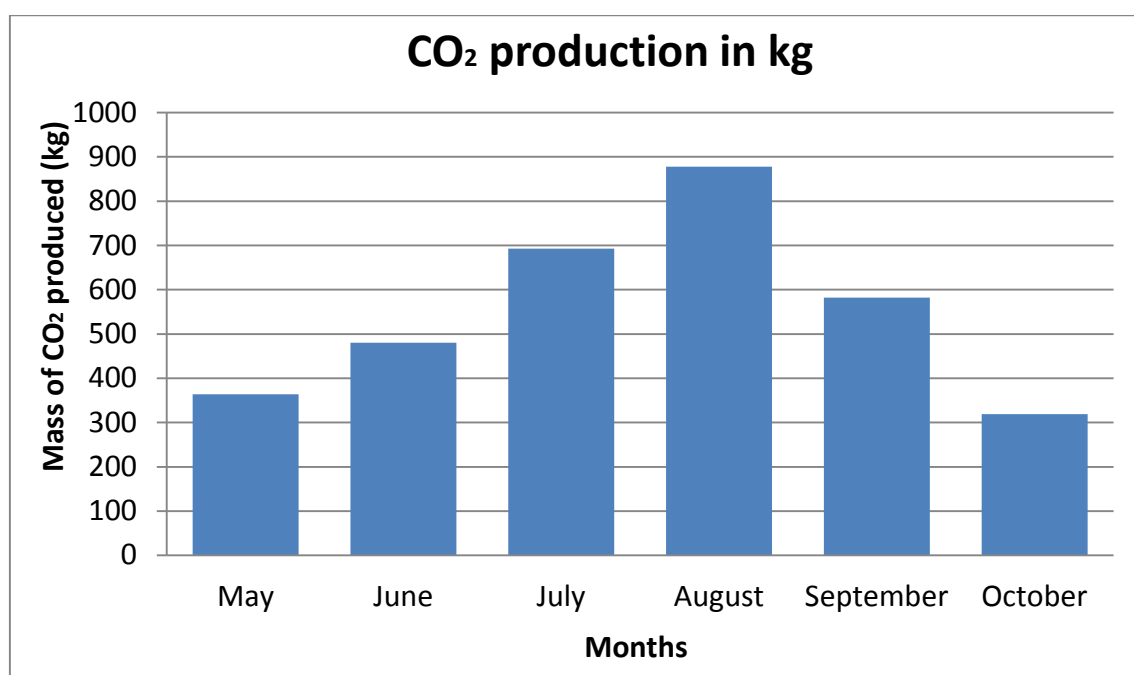

Fig.5.29: Monthly values of the CO<sub>2</sub> production in kg for the existing system of the oil furnace

The CO<sub>2</sub> production for the existing system, as Figure 5.29 shows, depends of the hotel occupancy. That is why during August, where the hotel has 100 % occupancy, it has its maximum production of CO<sub>2</sub> (878.1 kg), while in October, with the lowest occupancy, the hotel has only 318.7 kg of produced CO<sub>2</sub>.

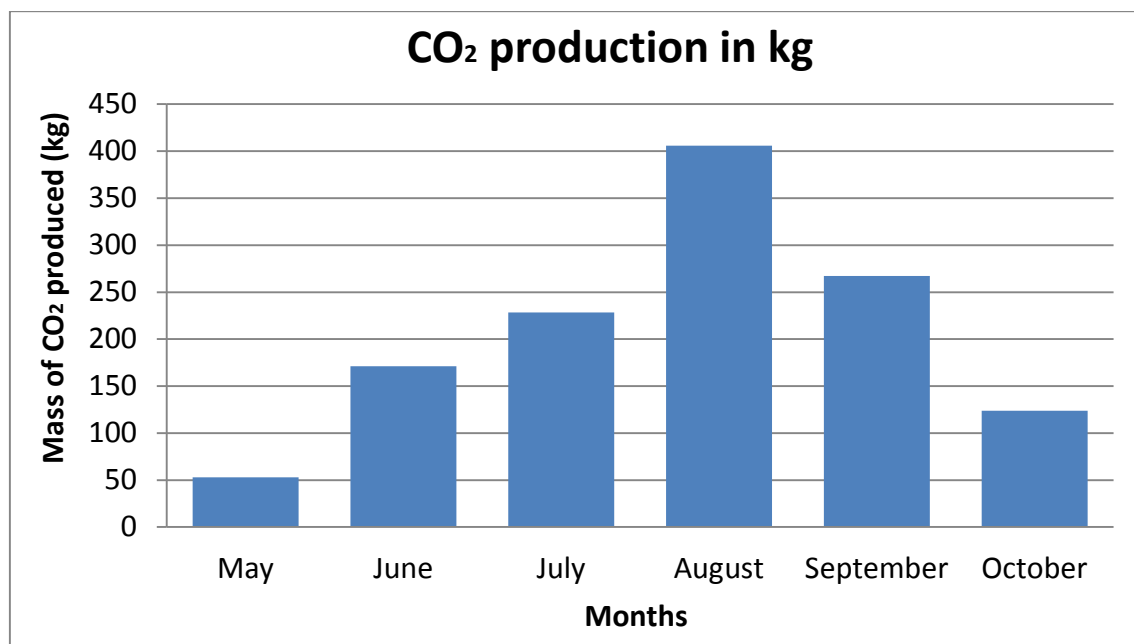

Fig.5.30: Monthly values of the CO<sub>2</sub> production in kg for the oil furnace and the flat plate collectors

By adding the flat plate collectors to the existing system of the oil furnace, the CO<sub>2</sub> production is reduced significant, as Figure 5.30 shows. Comparing only the month of August, with Figure 5.29, the CO<sub>2</sub> production is reduced from 878.1 kg to 406.0 kg, which is equal to a reduction by 53.8 %.

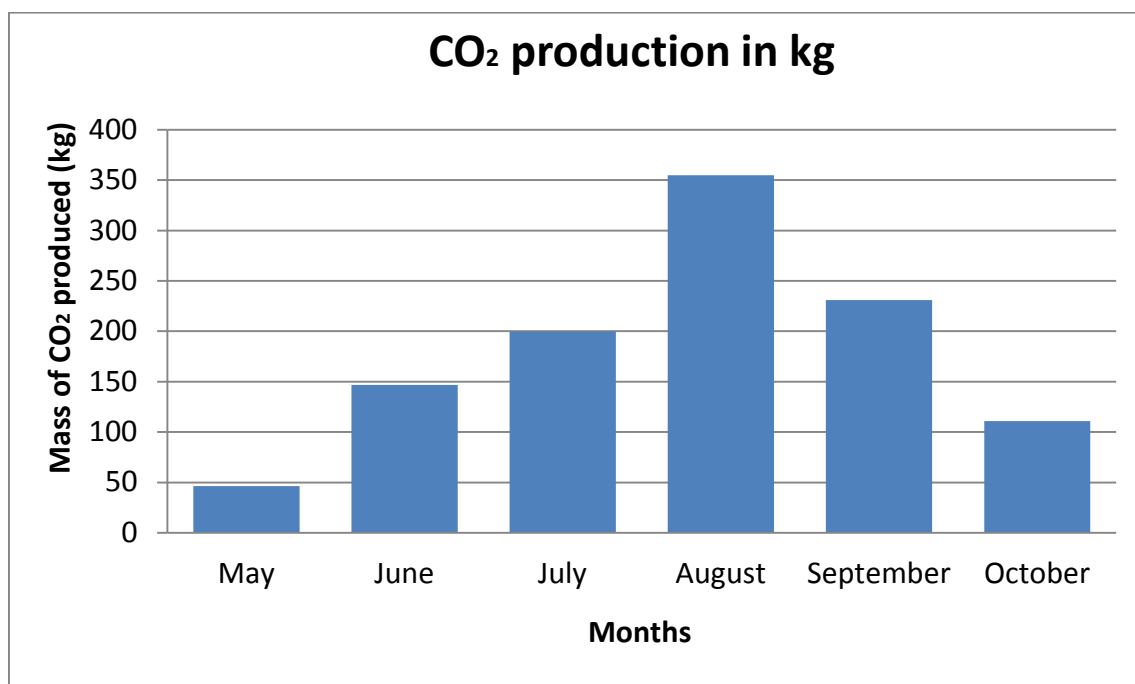

Fig.5.31: Monthly values of the CO<sub>2</sub> production in kg for the biomass furnace and the flat plate collectors

In the third scenario of the biomass furnace and the flat plate collectors, there is a further reduction of the CO<sub>2</sub> production, in comparison to the second scenario. More specifically, for the month of August, the CO<sub>2</sub> production is reduced from 406 kg to 355 kg. This corresponds to a reduction of 12.6 %.

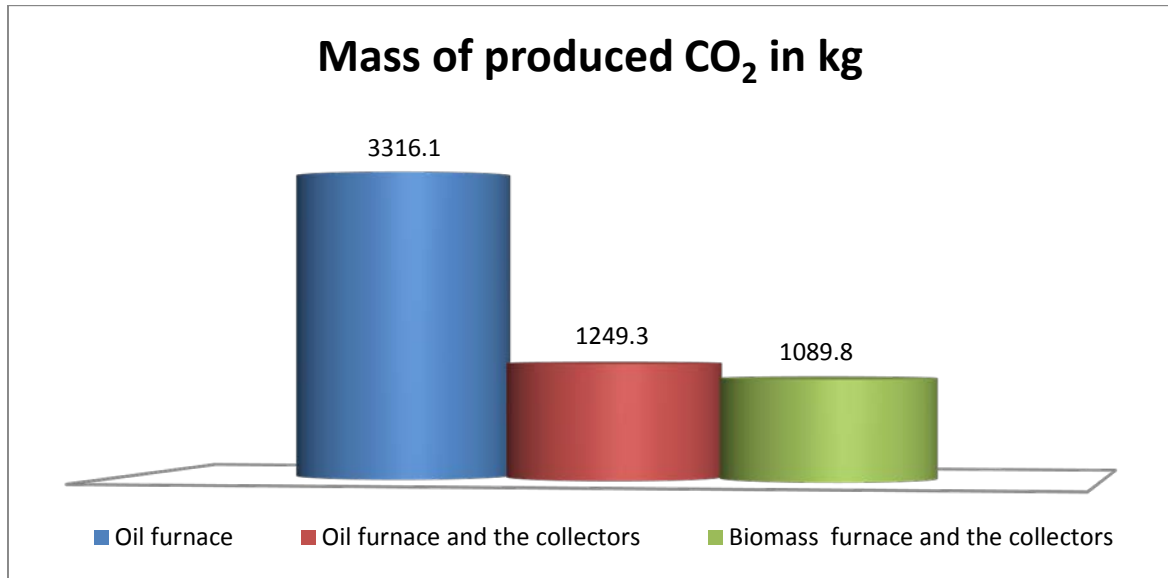

Fig.5.32: CO<sub>2</sub> production in kg for the three different cases for the whole period of operation of the hotel

According to Figure 5.32 the percentage of reduction of the CO<sub>2</sub> emissions can be calculated, which was achieved with the adding of the flat plate collectors both in the cases of the existing system of the oil furnace and also in the case of the biomass furnace and for the whole operational period of the hotel.

Figure 5.33, with the red color shows the reduction of the CO<sub>2</sub> emissions of the oil furnace and the flat plate collectors in comparison to the existing system of the oil furnace, while the green color shows the reduction of the CO<sub>2</sub> emissions of the biomass furnace and the flat plate collectors in comparison to the existing system of the oil furnace.

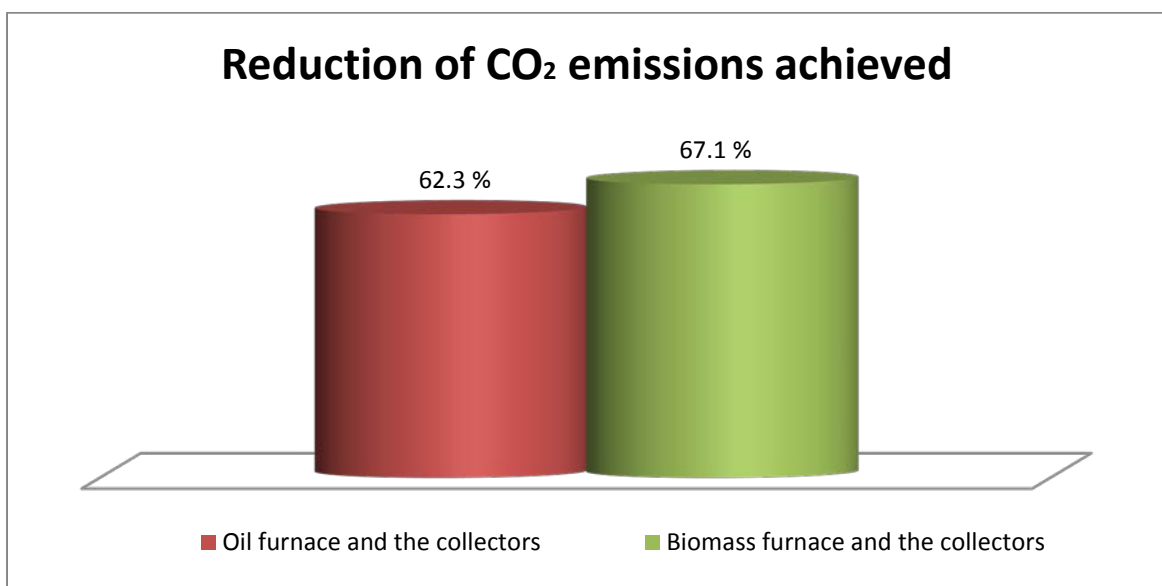

Fig.5.33: Reduction of the CO<sub>2</sub> emissions which was achieved with the installation of the flat plate collectors



Finally, Figures 5.34, 5.35 and 5.36 present the monthly values of the fuel costs for the existing system of the oil furnace, for the existing system and the flat plate collectors and for the flat plate collectors with the biomass furnace respectively. Figure 5.37 shows the fuel cost for the three different cases for the whole period of operation of the hotel.

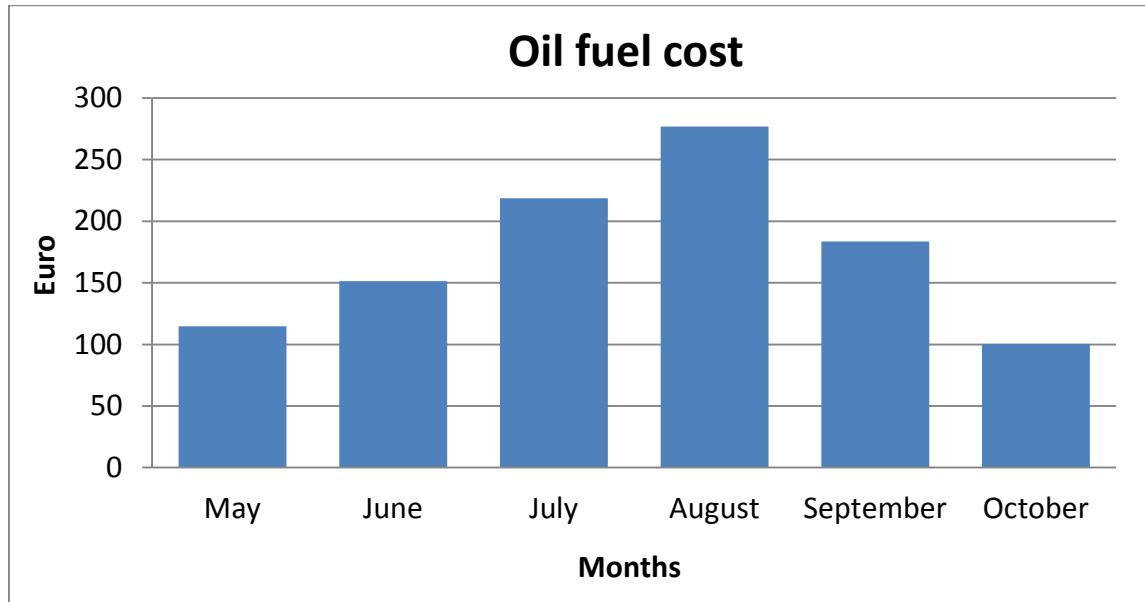

Fig.5.34: Monthly values of the oil fuel cost for the existing system of the oil furnace

The monthly values of the oil fuel cost for the existing system, in Figure 5.34, depend exclusively on the occupancy of the hotel, for each month of its operation, as well as the price of the fuel per liter.

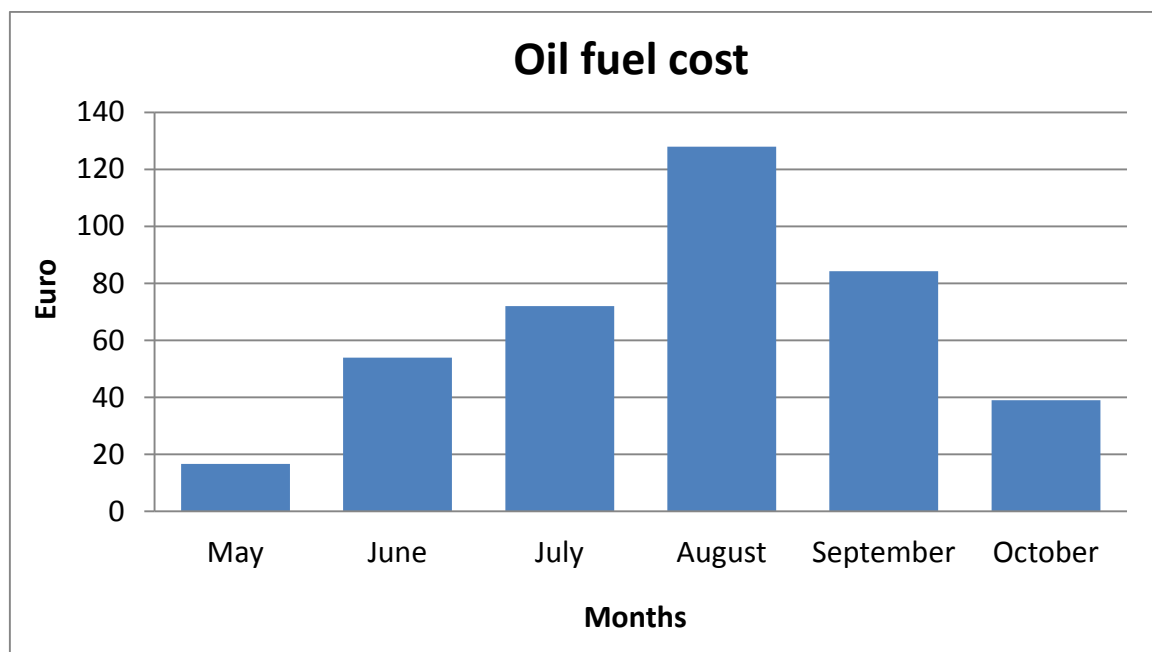

Fig.5.35: Monthly values of the oil fuel cost for the oil furnace and the flat plate collectors

By the installation of the flat plate collectors, to the existing system of the oil furnace, the reduction to the monthly values of the oil fuel cost, according to Figure 5.35, are obvious. The reduction depends on the direct solar radiation and the weather data of each month.

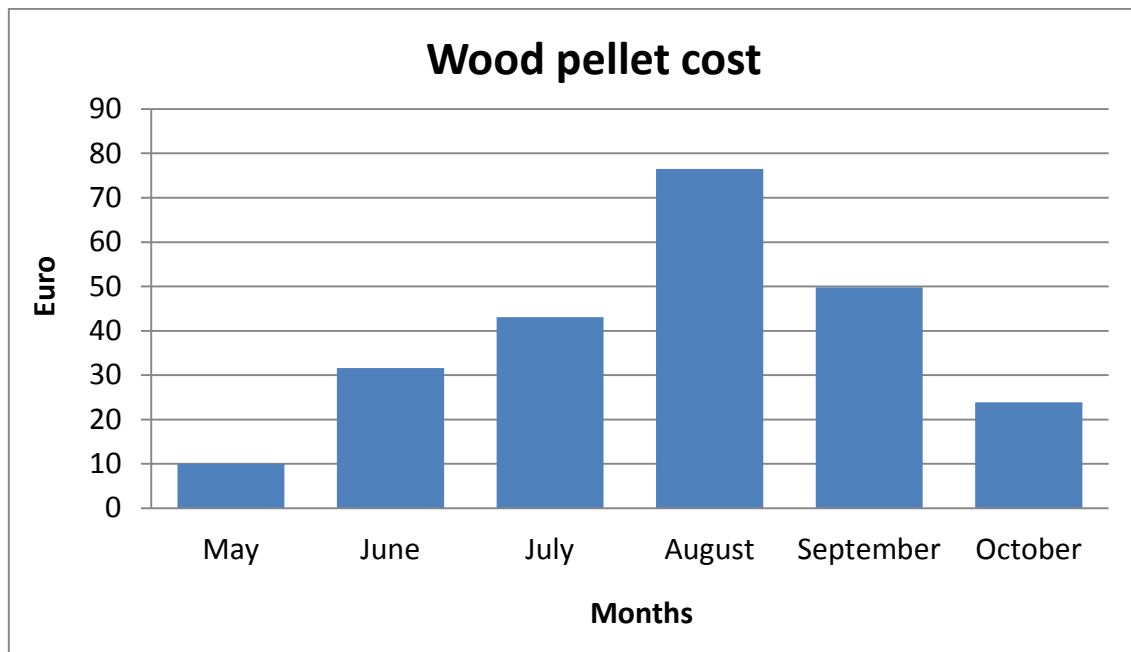

Fig.5.36: Monthly values of the wood pellet cost for the biomass furnace and the flat plate collectors

For the third scenario of the biomass furnace and the flat plate collectors, the monthly values of the wood pellets cost is further reduced, according to Figure 5.36, as the wood pellet has lower price than the light oil fuel.

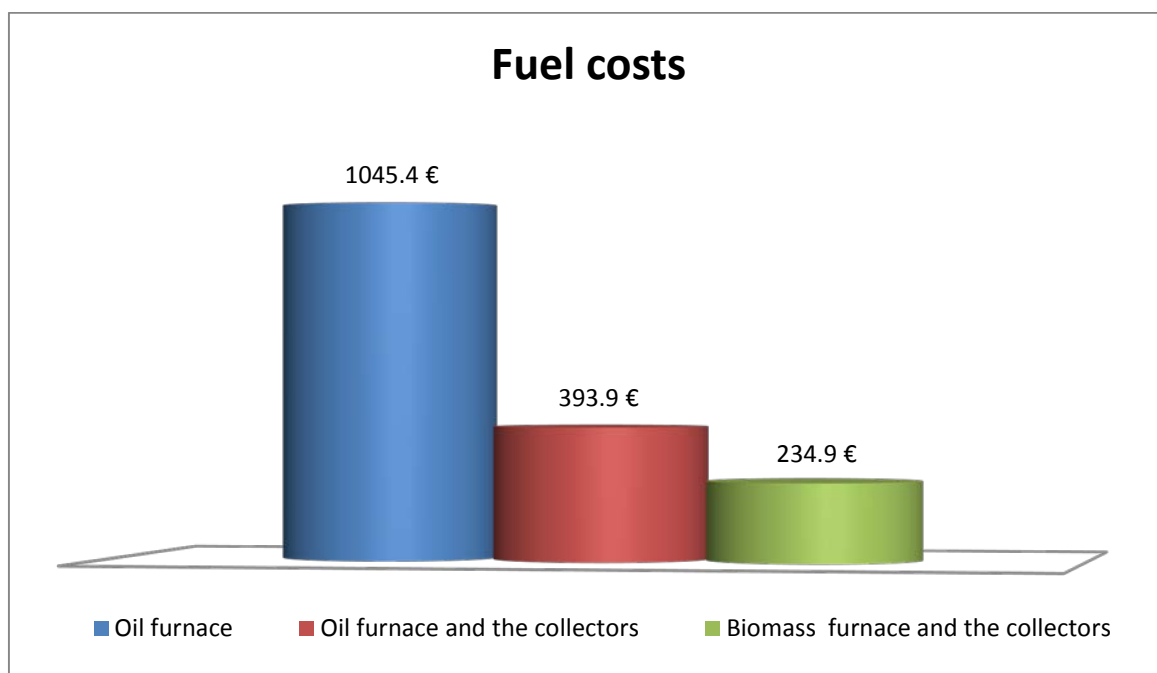

Fig.5.37: Fuel cost in euro for the three different cases for the whole period of operation of the hotel

Figure 5.37 proves that with the installation of the flat plate collectors there is a huge reduction of the operational cost of the hotel. This reduction is even bigger in the case that the owner decides to change the oil furnace with a biomass furnace.

According to Figure 5.37 the percentage of the coverage ratio can be calculated which was achieved with the adding of the flat plate collectors both in the cases of the existing system of

the oil furnace and also in the case of the biomass furnace. In Figure 5.38, the red color shows the coverage ratio of the flat plate collectors in the case of the oil furnace with the flat plate collectors, while the green color shows the coverage ratio of the flat plate collectors in the case of the biomass furnace with the flat plate collectors.

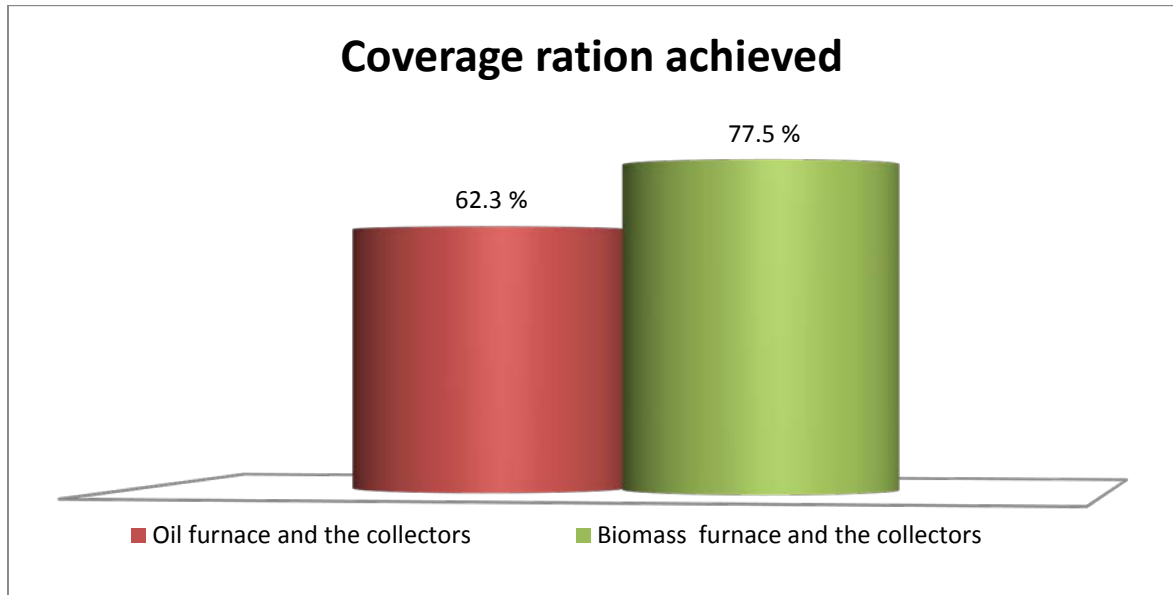

Fig.5.38: Coverage ratio which was achieved by adding the flat plate collectors

As it was mentioned in subchapter 4.4, the minimum coverage ratio of the flat plate collectors, according to the TOTE should be 60 %. After running the simulation in the case of the oil furnace and the flat plate collectors, and in the case of the biomass furnace and the flat plate collectors, Figure 5.38 proves that this coverage ratio was achieved in both cases.

## Chapter 6-Conclusions

Within the context of the present master thesis a simulation model in hourly bases, of a hybrid system for covering the needs of hot water of small hotel apartments was created. The simulation was carried out for three different scenarios: for the existing system of the oil furnace, for the oil furnace and the necessary surface of flat plate collectors, in order for the collectors to cover at least 60 % of the total demand, and finally for the flat plate collectors and a biomass furnace of the same nominal power as the oil furnace. The results of these simulations, for the whole period of operation of the hotel, for each month separately and for some characteristic days, were described in chapter 5.

From these results it is observed that with the installation of the flat plate collectors in the existing system of the hotel there was a reduction of the emissions of CO<sub>2</sub> by 2066.8 kg and a reduction of the total fuel cost by 651.49 €, for the total period of operation of the hotel. This proves that the saving that is succeeded in the system of the flat plate collectors with the oil furnace is at very satisfying levels.

However, this model of simulation is not perfect, as several of the data (length of the pipes, pressure drop in the pipes) were not calculated or were taken under rough estimation. Also as far as concern the peak hours of consumption of the hot water, they cannot be limited only to 5 hours per day. A more smoothed consumption profile would improve the simulation results. Finally, the temperature of the 50 °C that reaches the rooms and the daily consumption of 60 lt / person / day, although they were taken from the TOTEE, are considered too much.

A further research about the real needs of the specific hotel in hot water, as well as a reduction of the final temperature that reaches the rooms would reduce the necessary surface of the flat plate collectors.

For the system of the biomass furnace and the flat plate collectors it is observed that although the total mass of the fuel in kg is doubled, in comparison to the first case of the oil furnace and the flat plate collectors, the amount of the CO<sub>2</sub> emissions and the total cost are reduced. It is worth mentioning that the oil furnace and the biomass furnace have the same nominal power. Therefore it is concluded that the biomass furnace is considered as the more effective solution for the heating of water in the specific hotel.

The C.A.R.N.O.T. program has proved to be a very useful simulation tool for the successful finishing of the present master thesis. Thanks to its combination of the easy to use graphical interface of Simulink and the algorithms and differential equation solvers of MATLAB<sup>®</sup>, as well as the variable time steps that it possesses, it managed to simulate in an hourly base the whole period of the 6 months of operation of the hotel. The use of Renewable Energy Sources (R.E.S) is deemed necessary for the confrontation of the environmental and energy problems, especially in hotel application that require huge amounts of energy in order to heat the water of use, during their operation period. Especially when these hotels are located in Greece, which has enormous solar potential during the summer months, it's a shame this potential to be wasted and the hotels to use conventional sources of energy (such as oil, coal and petrol) for water heating

Greece has committed, as a member of the European Union, to cover by the year 2020 at least 20 % of its total energy needs with the use of RES. Unfortunately, while there are only five years left, Greece is still very far from this goal. For this reason, and in order to avoid penalties that may be imposed if Greece does not achieve its target of 20 %, is requested to overcome any bureaucratic problems and invest substantially in the development of RES.

## References

- [1] Renewable Energy Policy Network for the 21th Century, «Renewables 2010 Global Status Report», p. 15, September 2010
- [2] O. Edenhofer, R. Pichs Madruga, Y. Sokona, «Renewable energy sources and climate change mitigation», Cambridge University Press, pages 8-9, New York (2012)
- [3] Technology green energy-E-Online, (website: <http://technologygreenenergy-e-online.blogspot.de>)
- [4] Wikipedia, The Free Encyclopedia, (website: [https://en.wikipedia.org/wiki/Solar\\_energy](https://en.wikipedia.org/wiki/Solar_energy))
- [5] Σ.Ν.Καπλάνης, «Ηπιες μορφές ενέργειας II, Ηλιακή Μηχανική», εκδόσεις ΙΩΝ, σελίδα 31, 2004
- [6] Michael L. McKinney, Robert M. Schoch, «Environmental Science, Systems and solutions, Third edition», Jones and Barthlett Publishers, page 205-206, 2003
- [7] Energy and Environment: Clearing the Air (website: <http://environmentblog.nepa.org/>)
- [8] Hellenic association of photovoltaic companies (website: <http://helapco.gr/en/the-greek-pv-market/>)
- [9] Greek Solar Industry Association (EBHE) (website: <http://www.ebhe.gr/index.php?lang=en>)
- [10] Thermal Markets in Europe, Trends and Market Statistics 2012, page 7, June 2013
- [11] Geomodel Solar-Solargis (website: [http://solargis.info/doc/\\_pics/freemaps/1000px/ghi/SolarGIS-Solar-map-Greece-en.png](http://solargis.info/doc/_pics/freemaps/1000px/ghi/SolarGIS-Solar-map-Greece-en.png))
- [12] John Chadjivassiliadis, Costis Stambolis, «Project Helios: Can Solar Energy be Exported?, an assessment study», Institute of Energy for South-east Europe (IENE) , Athens, February 2012
- [13] Southface (website: <http://www.southface.org/>)
- [14] Alternative Energy Tutorials (website: <http://www.alternative-energy-tutorials.com/>)
- [15] John A. Duffie, William A. Beckman, «Solar Engineering of Solar Processes, Second Edition», A. Wiley-Interscience Publication, page 10, Wisconsin, June 1980
- [16] Socrates Kaplanis, Elina Kaplani, «Renewable Energy Systems, Theory, Innovations and Intelligent Applications», Nova Science Publishers, page 57-63, New York, 2013
- [17] Department of Energy and Mineral Engineering (EME) (website: <https://www.e-education.psu.edu/eme810/node/31>)
- [18] Nathanael Greene, «GROWING ENERGY, How Biofuels Can Help End America's Oil Dependence», Natural Resources Defense Council, page 3, December 2004
- [19] Stephen Karekezi, Kusum Lata, Suani Teixeira Coelho, «Traditional Biomass Energy, Improving its Use and Moving to Modern Energy Use», International Conference for Renewable Energies, Bonn, 2004
- [20] EM Energy Matters. Biomass: advantage and disadvantage (website: [http://library.Thinkquest.org/20331/types/biomass/advant.html](http://library.Thinkquest.org/20331/types/biomass/advant.html;);), 2010
- [21] R. Saidur, E.A. Abdelaziz, A. Demirbas, M.S. Hossain, S. Mekhilef, «A review on biomass as a fuel for boilers», Elsevier Ltd, page 2268, 31 January 2011
- [22] Peter McKendry, «Energy production from biomass (part 1): overview of biomass», Bioresource Technology 2002;83;37-46

- [23] Ben Urquhart, Gordon Boyce, «Woody biomass energy local renewable fuel for commercial, institutional and industrial facilities», Massachusetts Technology Collaborative, Renewable Energy Trust, June 2008
- [24] Khalid Rehman Hakeem, Mohammad Jawaid, Umer Rashid, «Biomass and Bioenergy, Processing and Properties», Springer International Publishing Switzerland, page 79, 2014
- [25] Abdullah A. Jaradat, «Genetic resources of energy crops: Biological systems to combat climate change», Australian Journal of Crop Science, 2010
- [26] Bioenergy Consult, Powering Clean Energy Future (website: <http://www.bioenergyconsult.com/>)
- [27] Christian Fischer, Emmanuel Gentil, Morten Ryberg, Almut Reichel, «Managing municipal solid waste — a review of achievements in 32 European countries», European Environment Agency Report, Copenhagen, 2013
- [28] MathWorks (website: [http://www.mathworks.com/help/pdf\\_doc/matlab/getstart.pdf](http://www.mathworks.com/help/pdf_doc/matlab/getstart.pdf))
- [29] MathWorks (website: [http://de.mathworks.com/help/pdf\\_doc/simulink/sl\\_using.pdf](http://de.mathworks.com/help/pdf_doc/simulink/sl_using.pdf))
- [30] Carsten Wemhöner, Bernd Hafner, Klemens Schwarzer, «Simulation of solar thermal systems with carnot blockset in the environment MATLAB® Simulink®», Solar-Institut Jülich, Germany
- [31] Bernd Hafner, Johannes Plettner, Carsten Wemhöner, Thomas Wenzel, «CARNOT Blockset, Version 1.0, Conventional And Renewable eNergy systems OpTimization Blockset, User's Guide», Solar-Institut Jülich and Scientific Computers GmbH, Germany
- [32] Meteororm, Irradiation data for every place on Earth (website: <http://meteororm.com>)
- [33] Climatemps.com (website: <http://www.corfu.climatemps.com/>)
- [34] Τεχνικό Επιμελητήριο Ελλάδος, «Αναλυτικές εθνικές προδιαγραφές παραμέτρων για τον υπολογισμό της ενεργειακής απόδοσης κτηρίων και την έκδοση του πιστοποιητικού ενεργειακής απόδοσης», Έκδοση ΔΠ1, σελίδες 7-8, Φεβρουάριος 2011
- [35] Bentone EnerTech Group (website: [http://www.bentone.com/wpcontent/uploads/17800717\\_Manual\\_Bentone\\_ST133KA-K\\_en.pdf](http://www.bentone.com/wpcontent/uploads/17800717_Manual_Bentone_ST133KA-K_en.pdf))
- [36] Τεχνικό Επιμελητήριο Ελλάδος, «Αναλυτικές εθνικές προδιαγραφές παραμέτρων για τον υπολογισμό της ενεργειακής απόδοσης κτηρίων και την έκδοση του πιστοποιητικού ενεργειακής απόδοσης», Έκδοση Β, σελίδα 24, πίνακας 2.2, Απρίλιος 2012
- [37] ΕΛΟΤ 1291, «Ηλιακή Ενέργεια – Μετεωρολογικά στοιχεία πόλεων της Ελλάδας για τις ανάγκες του προτύπου ΕΛΟΤ 879», 1991
- [38] Τεχνικό Επιμελητήριο Ελλάδος, «Κλιματικά δεδομένα Ελληνικών περιοχών», Έκδοση Β, σελίδα 52, πίνακας 6.1, Απρίλιος 2012
- [39] Volker Quaschnig, «Regenerative Energie systeme», editions Hanser, page 125, 2009
- [40] Τεχνικό Επιμελητήριο Ελλάδος, «Τεχνολογίες Ανανεώσιμων Πηγών Ενέργειας», σελίδα 118, Ιούνιος 2011
- [41] S.Kaplanis, "Solar Engineering II, Energy Sources", editions ION, p.161-169, 2004
- [42] Z. K. Morvay, D. D. Gvozdenac, «Fundamentals for analysis and calculation of energy and environmental performance. Applied industrial energy and environmental management», page 6 and 7, 2008
- [43] Υπουργείο ανάπτυξης και ανταγωνιστικότητας ( website: [www.fuelprices.gr](http://www.fuelprices.gr))

- [44] Γενική Δ/ση προστασίας καταναλωτή & εποπτείας της αγοράς Δ/ση πολιτικής & ενημέρωσης καταναλωτή τμήμα παρατηρητήριων τιμών & τιμολησιών, «Εβδομαδιαίο δελτίο επισκόπησης τιμών καυσίμων», Αθήνα 24-4-15
- [45] David E. Watkins, «Heating services in buildings», by editions Wiley-Blackwell, page 446, 2011



## Annex

### A.1 Completed questionnaire from the owner of the hotel

#### Information about the hotel

• Name of the hotel :	DEMIS APARTMENTS
• Location :	SIDARI-CORFU
• Telephone number:	(+30)6978032605
• Name of the responsible:	BABIS PAPASPILIOU
• Status of the responsible:	OWNER
• Email of the responsible:	mbambhs@yahoo.gr

#### Questionnaire

- Does the hotel is open seasonally or throughout the year?  
SEASONALLY
- If it is open seasonally, during which months?  
FROM MAY UNTIL OCTOBER
- How many 2-bed. 3-bed or 4-bed rooms does the hotel have?  
2 TWO-BED. 2 THREE-BED AND 5 FOUR-BED ROOMS
- How many people stay at the hotel per average each month, and what rooms do they occupy?

Month	Occupancy in persons	Occupancy in %	2-bed rooms	3-bed rooms	4-bed rooms
January	-	-	-	-	-
February	-	-	-	-	-
March	-	-	-	-	-
April	-	-	-	-	-
May	8.5	28.33	2	1.5	0
June	14	46.67	2	2	1
July	22	73.33	2	2	3
August	30	100.00	2	2	5
September	19	63.33	2	1	3
October	8	26.67	1	2	0
November	-	-	-	-	-
December	-	-	-	-	-

- Pool Heating
- Heating of areas (rooms. corridors. lobby. restaurant and others)
- Water of use (shower. washbasin)
- Kitchen
- Washing machines
- Others
- What mean do you use to heat the water in your hotel?
  - Boiler
  - Electric water heater
  - Gas
  - Solar collector
  - Other
- What are the name and the type of the burner that you use in order to heat the water?  
BENTONE ST 133K
- How much is the thermal power of the mean that you use to heat the water in your hotel?  
80000 KCAL / H
- How many liters is the storage tank of the hot water?  
350 LT
- What are the dimensions of the storage tank of hot water?  
LENGTH: 1.60 M    DIAMETER: 0.60 M
- Is the storage tank of hot water a standing cylinder or a horizontal cylinder?  
STANDING CYLINDER

	From	Until
Morning	09:00	11:00
Noon		
Afternoon	18:00	21:00
Evening		

- What are the peak hours of consumption of hot water?
- How much is the height of the east building up to the roof (where the tiles start)?  
5 M
- How much is the height of the west building up to the roof (where the tiles start)?  
5 M
- How much is the slope (in °) of the tiles in the east building?  
15°
- How much is the slope (in °) of the tiles in the west building?  
15°

## A.2 Description of the blocks used in the C.A.R.N.O.T. software program

For the development of the specific master thesis, as well as for the exportation of the appropriate diagrams and results, several blocks were used from the C.A.R.N.O.T. and the Simulink® library. These blocks are described below:

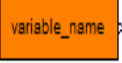
 It is inside the weather blockset of the C.A.R.N.O.T. library. By double clicking in the icon, the user can enter the block parameters, and set the data name inside the block exactly the same with the weather data file, so that it can read the data values from the MATLAB®'s workspace.

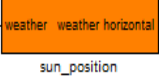
 This block is also inside the weather blockset of the C.A.R.N.O.T. library. By double clicking, a new window of the block parameters opens, and the user can set the latitude, the longitude and the longitude of time zone of the region.

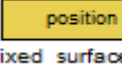
 This block is inside the weather blockset too. It is connected to the collector and by double clicking in the icon it is possible to set the collector's slope into a fixed position, to set the azimuth of the collector and its rotation angle.

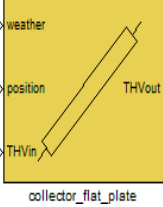
 This block is found in the heat source blockset of the C.A.R.N.O.T. library. By entering in the block parameters several parameters of the collector/s can be set, like the surface in  $m^2$  of the collector/s, the optical efficiency, the linear and the quadratic heat loss coefficient, the radiative loss coefficient, the length between inlet and outlet, the wind dependent heat loss, the effective heat capacity of the collector, the initial temperature and the number of the nodes of the collector.

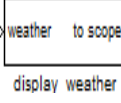
 This block is found in the outputs blockset of the C.A.R.N.O.T. library and its purpose is to transfer the clicked values of the: sun position, solar radiation, sky temperature, ambient temperature, precipitation, relative humidity, cloud index, pressure, wind speed, wind direction and incidence parallel or incidence perpendicular of the collector.

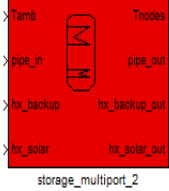
 This block can be found in the storage blockset of the C.A.R.N.O.T. library. By entering the block parameters the user can set a lot of parameters of the storage tank, like the diameter, the volume, the position of the tank (if it is an standing or a lying cylinder), the heat loss coefficient at the walls the effective axial conductivity, the heat loss coefficient at the bottom of the tank and the initial temperature of the storage tank.

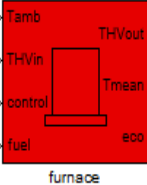
 This block is inside the heat source blockset of the C.A.R.N.O.T. library. The block parameters of the furnace comprise the setup of its nominal power, the heat loss coefficient, the linear pressure drop in the mass flow, the quadratic pressure drop in the mass flow, the volume of the boiler, the number of the nodes and the initial temperature.

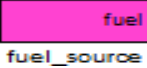
 This block is connected to the furnace and is available at the misc blockset of the C.A.R.N.O.T. library. In the block parameters the user can set the type of the fuel, the temperature, the stoichiometric air demand, the pressure, the heat without/with condensation, the condensation temperature, the price of fuel per kg and the mass fraction.

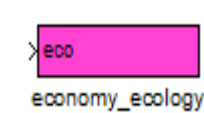

It can be found at the misc blockset like the above block of fuel source. By right clicking of the mouse in the icon, the user may look under mask and see valuable information about the mass of the fuel, the thermal and electric energy, the fuel cost and the mass production of  $H_2O$ ,  $CO_2$ ,  $O_2$ ,  $SO_2$ ,  $N_2$ ,  $NO_x$ ,  $CO$  and  $C_xH_y$ .

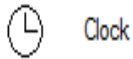

This block can be found in the sources blockset of the Simulink® library. As it is already mentioned in the subchapter for the Simulink®, the clock is used in order to create a time index for plotting purposes.

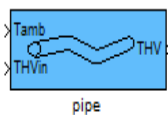

It is placed in the hydraulics blockset in the C.A.R.N.O.T. library. In the block parameters they can be set the diameter and the length of the pipe, the number of the nodes, the heat loss coefficient, the effective conductivity, the capacity of the pipe wall per length, the initial temperature, the roughness of the pipe and the number of the bends.

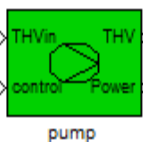

This block is part of the pumps blockset of the C.A.R.N.O.T. library. The mass flow rate, the type of fluid (water, water with glycol etc), the percentage of the fluid mix, the diameter at in and outlet, the electric power consumption, the system pressure, the capacity of the pump and the initial temperature can be set in the block parameters of the pump.

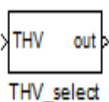

It is located in the outputs blockset of the C.A.R.N.O.T. library. The user can select and tick some of the values of flow identifier, temperature, mass flow, pressure, fluid ID, fluid mix, diameter and constant or linear or quadratic pressure drop in the block parameters of the THV\_select.



It is located in the sinks blockset of the Simulink® library and in the outputs blockset of the C.A.R.N.O.T. library. Its purpose is to show the results of the simulation.

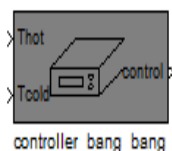

It is found in the control blockset of the C.A.R.N.O.T. library. It is practically a hysteresis controller for thermal systems. In the block parameters the user can set the delta  $T_{on}$ , the delta  $T_{off}$  and the maximum temperature. If the temperature  $T_{hot}$  or  $T_{cold}$  exceeds  $T_{max}$ , the controller will switch off the control signal.



This block is part of the misc blockset of the C.A.R.N.O.T. library and in the Signals and Systems blockset of the Simulink® library. Its purpose is to terminate the output signals and prevent warnings from any unconnected ports.

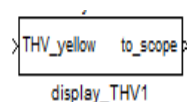

This block is located in the outputs blockset of the C.A.R.N.O.T. library. By double clicking in the icon the user can enter the block parameters and tick the value which is going to be sent in the scope for displaying. In the output blockset, the user can choose between display\_THV1, display\_THV2, display\_THV4 or display\_THV6.

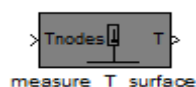

This block is inside the control blockset of the C.A.R.N.O.T. library. It is used in order to measure the temperature and it can be combined with the storage tank in order to get the node temperature. In the parameters of the block the user can set the relative position, the time delay and the initial temperature.

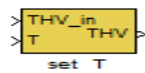

This block is part of the misc blockset of the C.A.R.N.O.T. library and it is used in order to set the temperature in the Thermo-Hydraulic-Vector.



This block can be found in the loads blockset of the C.A.R.N.O.T. library and the Sources blockset of the Simulink® library. It outputs a waveform that the user sets by double clicking on the block, and setting the time and output values.



This block is inside the loads blockset of the C.A.R.N.O.T. library. It is used as a constant pump that sets a constant mass flow rate. By double clicking on the block, the user can set different parameters as the temperature, the mass flow, the type of fluid and the percentage of the mix, the diameter and the system pressure.



This block is part of the misc blockset of the C.A.R.N.O.T. library. Its purpose is to output a constant value, which can be set in the block parameters. If the Interpret vector parameter as 1-D is clicked, then a constant value is outputted, or else the output is a matrix with the same dimensions as the constant values.



This block is found in the Signals and Systems of the Simulink® library. It turns multiple scalar, vector or matrix signals inputs into one output. The number of the inputs signal can be defined in the parameters of the block, by double clicking on the icon.



The Gain block is located in the math blockset of the Simulink® library. Its purpose is to generate the output by multiplying the input value with a specific gain factor, which can be set in the parameter of the block.

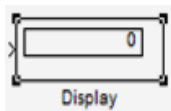

The specific block is encountered in the sinks blockset of the Simulink® library and in the outputs blockset of the C.A.R.N.O.T. library. Its purpose is to display the input that it gets. The amount of the data and the time step at which the data are displayed is defined at the block parameters.

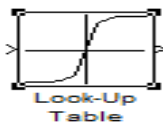

This block is inside the Functions and Tables blockset of the Simulink® library. It is used to map input and output values by using linear interpolation, which can be set by double clicking on the block and entering the parameters.



This block is found in the Signals and Systems of the Simulink® library. It does the exact opposite work of the Mux block, which was described 4 blocks above, meaning that it turns a single scalar, vector or matrix signal input, into multiple outputs. The number of the input signal can be defined in the parameters of the block, by double clicking on the icon.

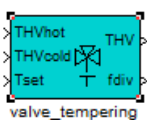

It is found in the Hydraulics blockset of the C.A.R.N.O.T. library. It is used with the flow mixer fixed rate block. Its purpose is to mix cold and hot fluid in order to set a desired temperature, without calculating the pressure drop.

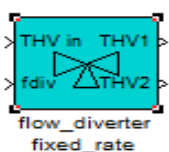

This block is also found in the Hydraulics blockset of the C.A.R.N.O.T. library. It is used with the valve tempering block. Its purpose is to divert the incoming mass flow into two different mass flows in such a way, that the total incoming is equal to the diverted ones.